

CNC precision turning machine for simultaneous machining on main and counter spindle



Technical data:

Tool turret

VDI 25 – 12 positions
optional 16 or 48 positions
with individual drive 6.000 rpm

Bar capacity

Main spindle 16/26/32/42 mm

Spindle speed

Main spindle and counter spindle up to 15.000 rpm

Control system

SIEMENS Sinumerik 840Dsl / Fanuc 310 is-A

Dimensions L x W x H

2.950 x 2.010 x 2.000 mm (2.570 mm)

Machine variants:

B2

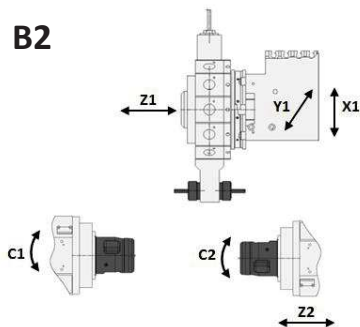

B6

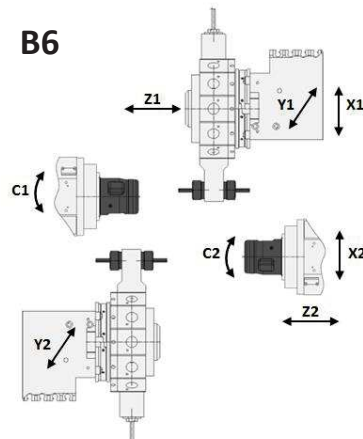

B10

