

# 08 Series

Fast, compact machining centers  
for high precision and various applications

**chiron**

---

[www.chiron.de](http://www.chiron.de)



DZ 08 W  
Double-spindle machining center with a workpiece changing unit 0°/180° and NC rotary table.

---

# Compact, fast & precise

## As multifaceted as your manufacturing tasks

The machining centers of the CHIRON Series 08 are among the most versatile machines in the compact class. These high-performance centers are characterized by:

- Reliably high productivity
- Highest precision
- Minimum floor space requirements
- Fast set-up
- Simple operation
- High stability
- High dynamics
- Easy maintenance

With its modular design and the resulting numerous configuration possibilities, every 08 basic machine can be assembled into a perfect individualized solution.

Your benefits: Low production costs combined with high processing quality and unprecedented speed within the smallest possible space.

# For uncompromising quality

down to the smallest detail

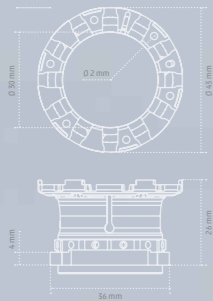

Precision Technology  
Board holder for electronic components made of stainless steel 1.4305 [Ø 50 mm]

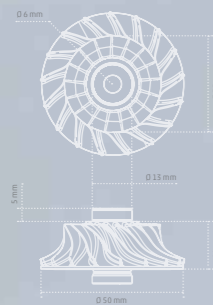

Automotive  
Compressor wheel for turbochargers made of Al 3.1924 [Ø 49 mm]

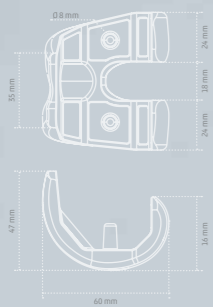

Medical Technology  
Knee implant made of cobalt-chromium steel 2.4979

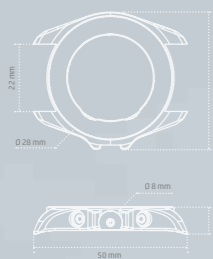

Precision Technology  
Jewellery and watch components with great accuracy and surface quality, such as stainless steel cases, main plates, watch band links etc.

## We love perfection ...

that's why we view every detail as an exciting challenge. Whether automotive, aerospace, mechanical engineering, medical or precision engineering - the high-quality machining centers of the CHIRON 08 Series reduce processing times, produce excellent surfaces, compress your manufacturing process into the smallest space possible and are the perfect tools to implement your product ideas quickly with micron-level precision.



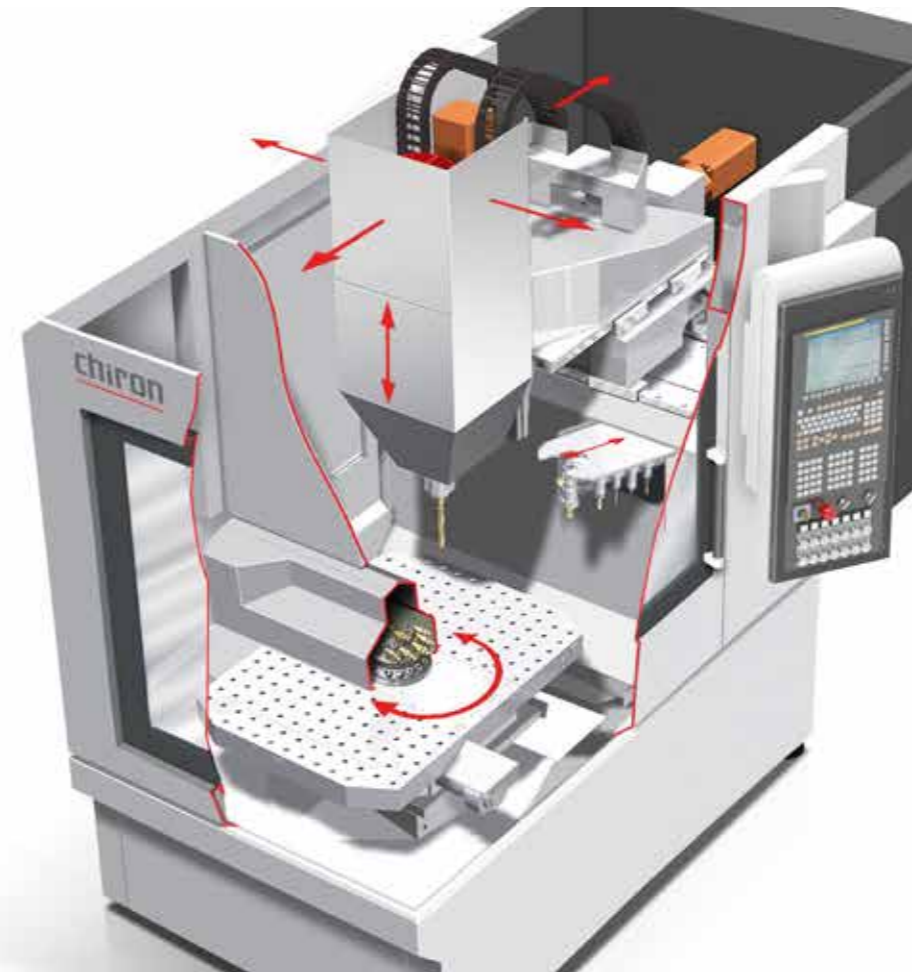
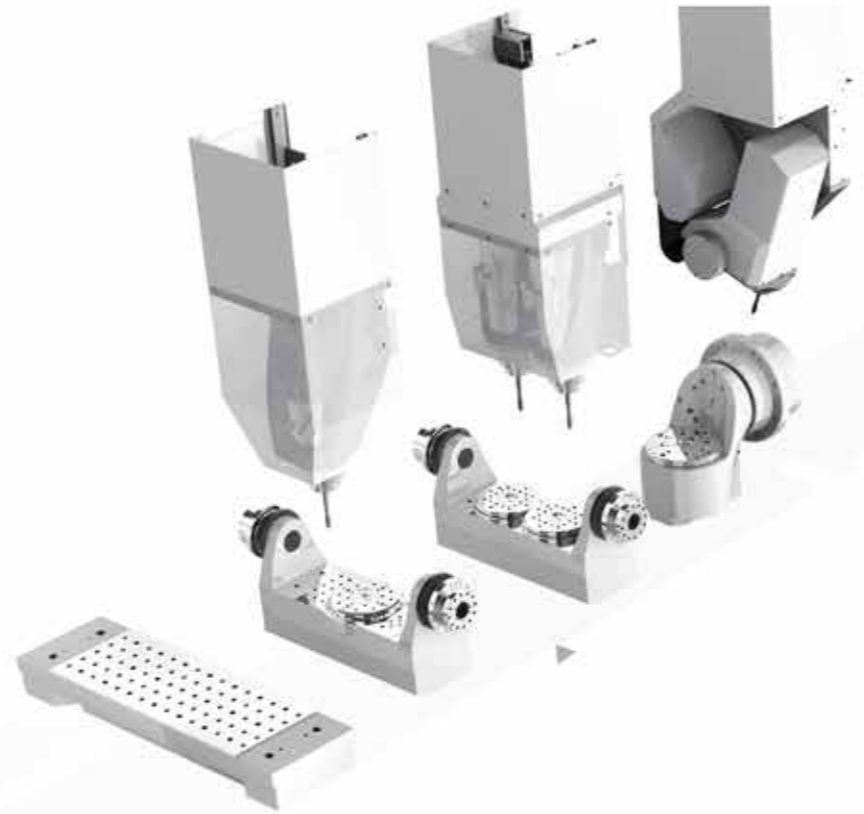

FZ 08 W: Compact and fast single-spindle machining center with integrated workpiece changing device 0°/180° for easy loading and unloading during machining.

Highest precision: glass scales, digital drive technology and absolute path measurement systems allow high acceleration with equally high contour accuracy.



# Perfectly matched high-tech modules

to meet the highest requirements and for customized production

## Modular concept:

- Vertical traveling column principle
- Compact installation area from width 1,260 mm x depth 2,700 mm
- Steel mineral cast machine bed
- High rigidity and thermal stability
- Motor spindles with water cooling
- Precision glass scales on all axes
- Dynamic direct drives and precision guides
- Robust CHIRON rotary axes
- Fully enclosed work area, stainless steel covers
- Smooth, steep walls for ideal chip flow directly into the chip conveyor
- Ergonomic operating and loading concept
- Service friendly access to all auxiliary units
- Low-maintenance and durable





## Spindles & spindle systems:

-  Proven single-spindle machining centers in the vertical traveling column design.
-  Highly productive double-spindle machining centers with a spindle clearance of 200 mm.
-  Machining centers with NC swivel head with infinitely programmable positioning in the range of -20° to +115°. Very robust, opposing pre-tensioned backlash-free precision gear with direct measuring system.

## Tool changing systems:

-  Automatic tool change with the pick-up method (as fast 0.8 s) in single or double version for the provision of up to 80 tools (HSK 32 or HSK 40).

## Table options:

-  Fixed table with plenty of space for devices and NC rotary table assemblies for multi-sided machining in one set-up.
-  2-axis tilt rotary table in BC kinematics with a face plate (diameter: 245 mm). The face plate provides the option of hydraulic or pneumatic workpiece clamping.
-  2-axis tilt rotary table with AC kinematics and one or two face plates (diameter: 195 mm) for single or double-spindle multi-sided machining.
-  Workpiece changing device with table loading capacity of up to 200 kg per side and large clamping surfaces (2 x 660 x 350 mm), borehole pattern, central distributor for energy supplies.

# The right machine for each component

## Variants and extension options

### Process advantages

- Traverse paths X-Y-Z max. 450-270-360 mm
- Power max. 18 kW
- Spindle clearance 200 mm
- Spindle speed max. 54.000 rpm
- Chip-to-chip time 2,1 s
- Axis acceleration X-Y-Z max. 10 / 13 / 12 m/s<sup>2</sup>
- Rapid feed rates max. 75m/min
- Number of tools max. 96
- Tool taper HSK 32 / HSK 40
- Tool weight max. 1,2 kg
- Tool diameter max. 100 mm
- Tool length max. 200 mm
- Automatic workpiece change in 2,0 s
- High process stability with filigree machining



**FZ 08 W:** Machining center with a workpiece changing device, NC rotary table and 2-way clamping device with fast CHIRON pick-up tool changer.

**FZ 08 five axis precision\*:** Fast and compact precision machining center with a 2-axis tilt rotary table for 5-axis simultaneous and complete machining. Workpieces can be machined with high surface quality in one set-up.

**DZ 08 five axis precision\*:** Fast and compact double-spindle machining center with 2-axis tilt rotary table and two face plates. 5-axis simultaneous operations are carried out using high-performance control options.

**FZ 08 S profile system:** Multifunctional machining center for the complete machining of workpieces of different lengths from extruded profiles. Whether milling, tapping, countersinking, reaming or cutting – everything is possible.

		Spindles & spindle systems				
		Automatic tool changer				
		Table options				
		S	FX	W	MT	MP
	FZ	CHAIN	<b>FZ 08 S</b>	<b>FZ 08</b> five axis <b>FZ 08</b> five axis precision*	<b>FZ 08 W</b>	<b>FZ 08 S</b> profile system
	DZ	CHAIN		<b>DZ 08</b> five axis <b>DZ 08</b> five axis precision*	<b>DZ 08 W</b>	
	S-HEAD	CHAIN	<b>FZ 08 S</b>			<b>FZ 08 S</b> mill turn <b>FZ 08 S</b> mill turn precision*

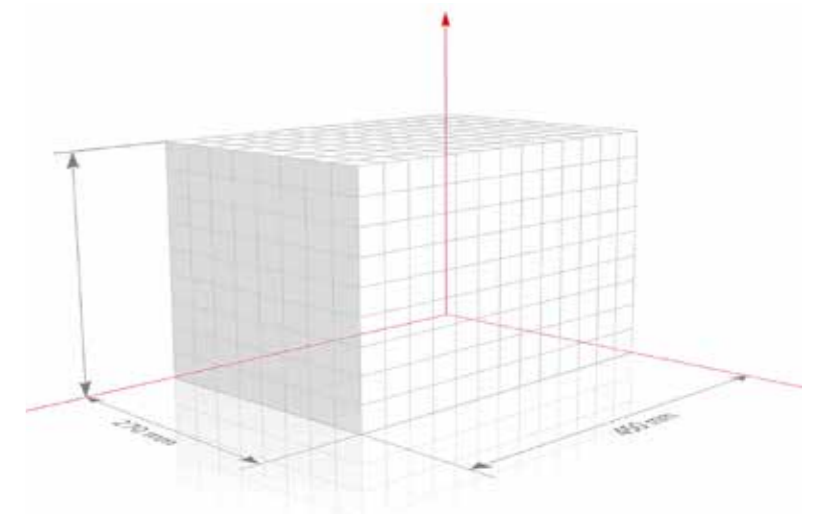

Flexible work areas and maximum traverse paths: X=450, Y=270, Z=360 mm

# Variety and flexibility as a foundation

Proven technology and the highest precision standards

Your advantages with the CHIRON fixed table or workpiece changing device:

- 3-axis basic machining center based on the vertical traveling column principle
- Compact installation area from width 1,260 mm x depth 2,700 mm
- Steel mineral cast machine bed
- High rigidity and thermal stability
- Clear, easily accessible work area
- Work area for larger workpieces or multiple set-ups
- Automatic tool change with the pick-up method
- Short chip-to-chip times 2.1 s
- Loading and unloading during machining time with a workpiece changing device (workpiece change time 2.0 seconds)
- Workpiece changing device with central splash guard and optimal accessibility
- Expandable to 4 axes with the basic device or to 5-axis machining with the 2-axis tilt rotary table
- Optional fully integrated automation solutions (VariocellUno)

**FZ 08 S:**  
Compact and flexible precision machining center with fixed table and automatic tool change with the pick-up method. Ample space for devices or NC rotary table installations for multi-sided machining.

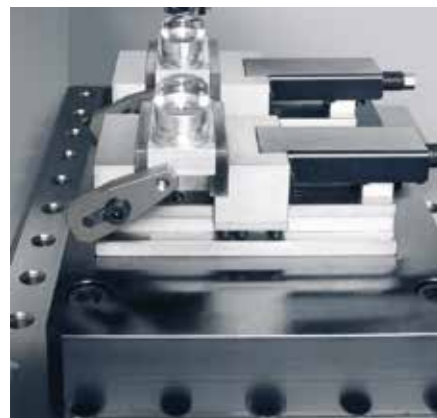

**FZ 08 W:**  
Machining center with a workpiece changing device, for simultaneous loading and unloading of the machine.



**Workpiece changing device 0°/180°** with ample space for devices and NC rotary tables, such as the installation of a workpiece swivel device as the fourth NC axis.

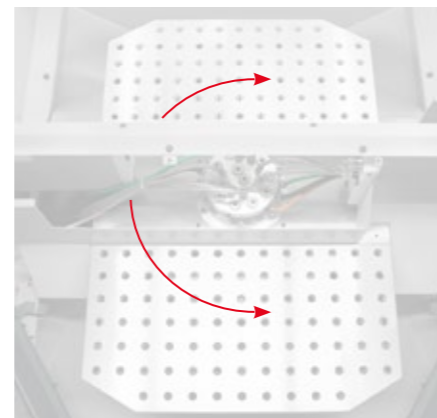

**FZ 08 S:**  
Fast and compact precision machining center. Highest productivity through tool-changing times starting from 0,8 seconds

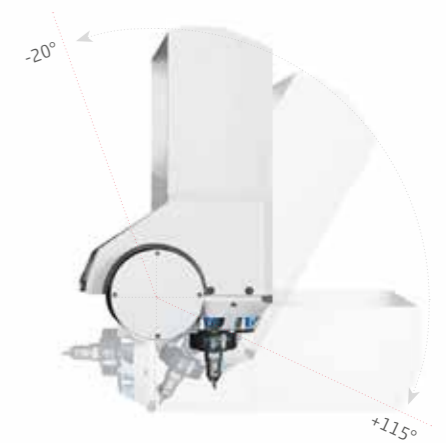

**FZ 08 S:**  
Compact precision machining center with a fixed table and NC swivel head with infinitely programmable positioning (-20°/+115°).

The fixed table / workpiece changing device provides ample space for devices or NC rotary table assemblies

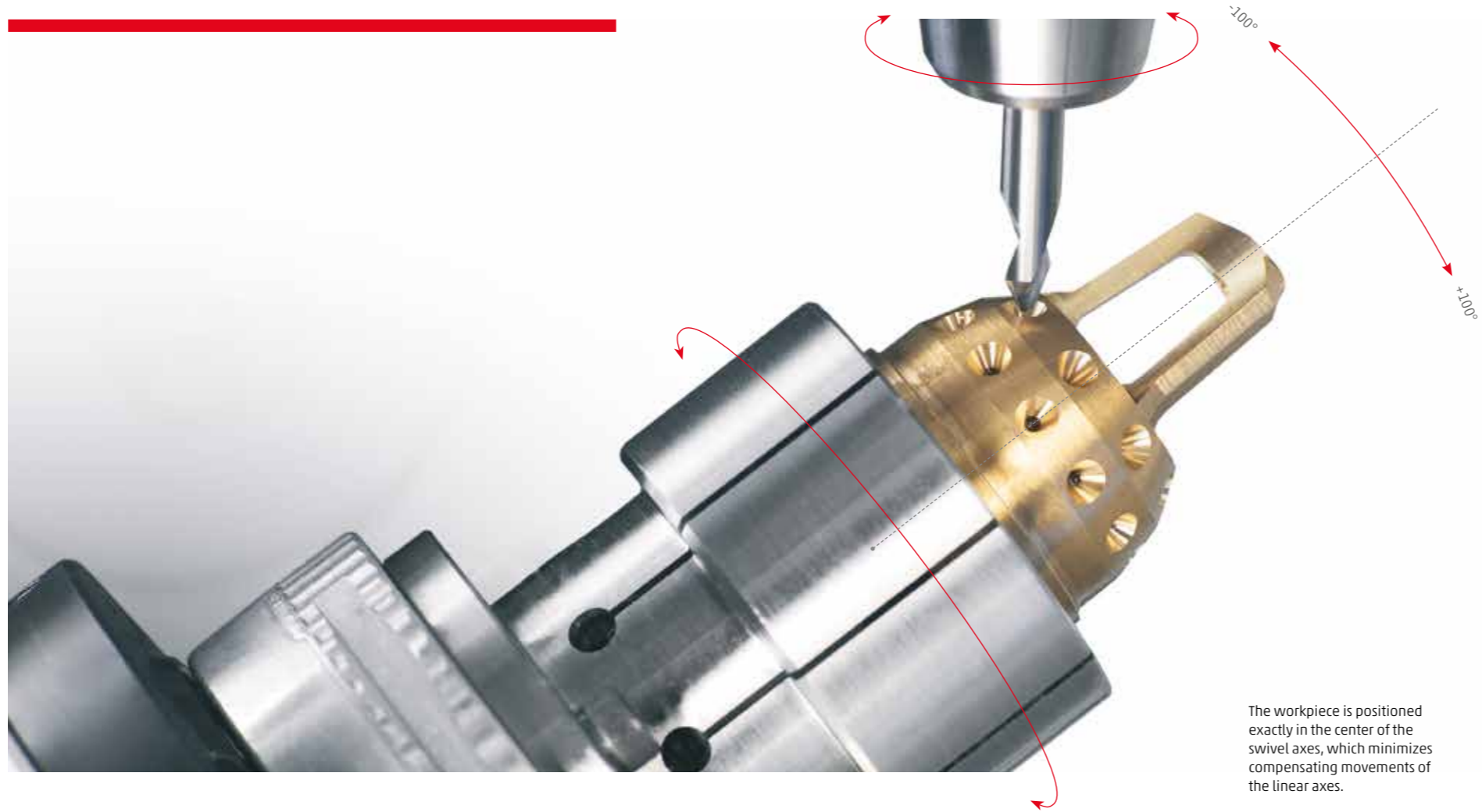

The workpiece is positioned exactly in the center of the swivel axes, which minimizes compensating movements of the linear axes.



**FZ 08 S five axis:** Integrated 2-axis rotary table (BC kinematics), maintenance-free torque drive technology and automatic tool change with the pick-up method.



With the **CHIRON five axis** you achieve shiny surfaces, extremely fine structures, the smallest bore holes, grooves, pockets, fits and geometries with tolerances of a few microns – reliably, quickly and economically.

# Precision and dynamics at the highest level

Complete machining with CHIRON five axis

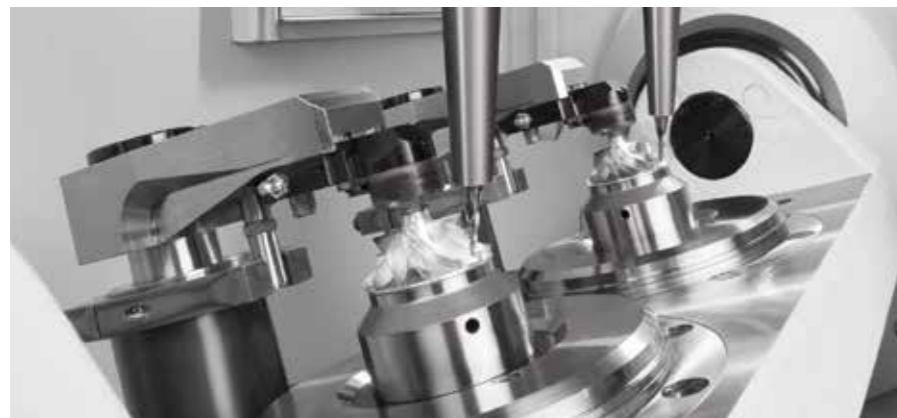

**DZ 08 S five axis:**  
Double productivity in a small space  
The smallest and fastest double-spindle machining center with a 2-axis tilt rotary table (AC-kinematics) for efficient complete machining with five simultaneously controlled axes.

Spindle clearance	200 mm
2-axis tilt rotary table CASD	160-2
- Swivel range	± 120°
- Face plates	2 x Ø195 mm
Chain magazine / tool places	2 x 16
Tool change time	0,9 s

## Your advantages with CHIRON five axis

- Compact installation area from width 1,580 mm x depth 2,540 mm
- Steel mineral cast machine bed
- High rigidity and thermal stability
- Highest precision in positioning and simultaneous operation
- Motor spindle speeds of up to 40,000 rpm
- Excellent surface quality
- Integrated CHIRON 2-axis tilt rotary table with direct measuring systems
- Integrated 6-way energy supply for clamping device on the face plate
- Zero-point clamping systems can be integrated
- 4th axis with swivel range up to +/- 100° (BC) or +/- 120° (AC)
- 5th axis with torque drive up to 6,500 rpm for turning work
- Optional fully integrated automation solutions (VariocellUno)

# Manufacture quality products up to 50% faster

with CHIRON multi-spindle machining

## Your advantages with CHIRON multi-spindle machining:

- Compact installation area from width 1,580 mm x depth 3,300 mm
- Two spindles – double productivity – energy saving of more than 35%
- Water-cooled motor spindles up to 40,000 rpm
- Spindle clearance 200 mm
- High rapid feed speeds up to 75 m/min
- Highest precision in positioning and simultaneous operation
- Precision glass scales on all axes
- Minimum chip-to-chip times 2.1 s
- CHIRON 2-axis tilt rotary table optional
- Optional fully integrated automation solutions (VariocellUno)

### DZ 08 S five axis:

The smallest and fastest double-spindle machining center with a 2-axis tilt rotary table (AC kinematics) for economical five-axis complete machining.



### DZ 08 W:

Perfect combination of two spindles, workpiece changing device 0°/180° and NC rotary table with 4-way clamping device for multi-sided machining.



### The multiplier effect – more spindles, more cutting, more profit:

The combination of 2 spindles and a 4-fold clamping device results in a cost saving of up to 50%. Doubled productivity on one machine means a reduction in machining time of nearly 50%. There is also the option of multi-sided machining through NC controlled round axis.

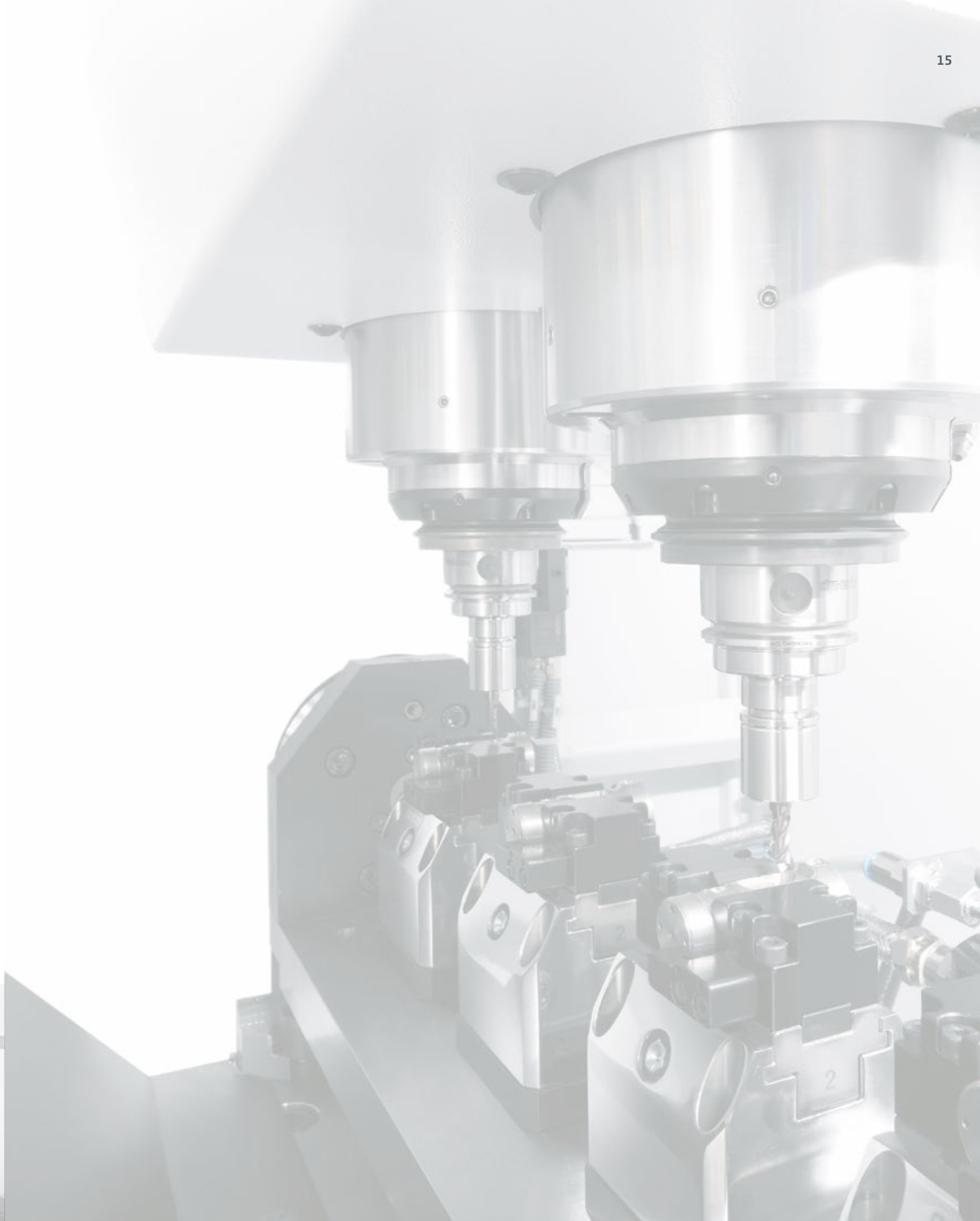



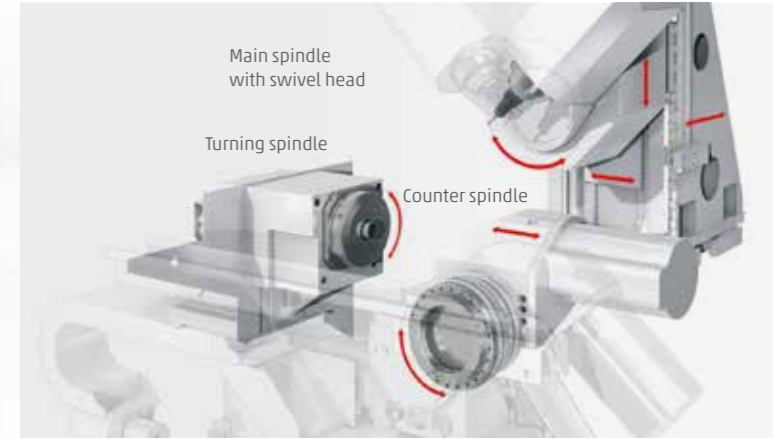

The modular design of the FZ08 MT allows a customized configuration for various applications in numerous industries. The MT machining center is equipped with the new CHIRON swivel head with a torque drive for higher precision and surface accuracy.



The swivel head axis is aligned with the tool center point for maximum accuracy during simultaneous machining. (Eliminating the need for compensatory movement in the milling axis)

# PRECISION<sup>+</sup> for more precision

High-precision 6-sided complete machining on less than 3,1m<sup>2</sup>

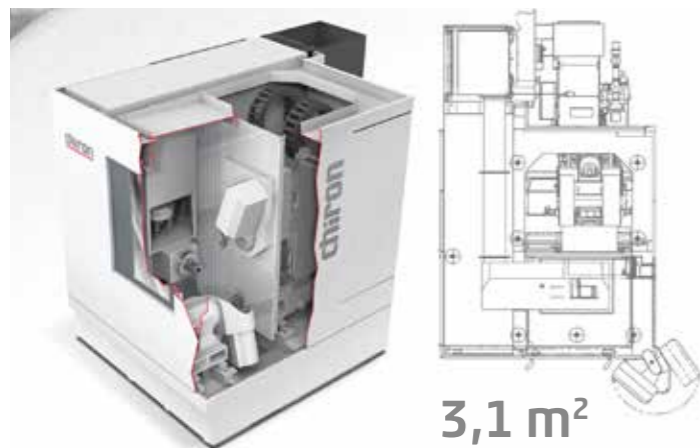

3,1 m<sup>2</sup>

**FZ 08 S mill turn precision\***  
CHIRON MT: The fastest 6-sided complete machining with swivel head, turning spindle and opposed spindle for milling and turning from bars.

## Your advantage - compact, highly-precise, efficient, flexible

- Highest precision and excellent precision surfaces
- Direct torque drive for optimal swivel head kinematics
- Multi-functional machining in a single machine (Milling, turning, drilling, threading, etc.)
- Fully-fledged rotation function by turning spindle (up to 8,000 rpm / IT5)
- Counter spindle for reverse-turning and 5-axis simultaneous milling
- Optimized use of the working area through ingenious placement of the counter spindle
- Reduce processing times with complete 6-sided machining from bar (up to 42 mm Ø)
- Wear-free, highly dynamic linear direct drive axes in X, Y and Z
- Direct measuring system in all axes
- Very compact footprint (3,1 m<sup>2</sup>)
- Individual material supply solutions (bar loader / bar loading magazine / VariocellUno/System)
- Integrated precast removal (slide, drawer)
- Service friendly access to all auxiliary units (FluidTower)

# Multi-functionality by the meter

Complete machining of extruded profiles

## Your advantages with CHIRON profile system

- Automatic production of workpieces, one after the other
- Profile sizes up to 80 x 80 mm
- Lower costs per unit due to high productivity of the process
- High production quality by machining in one set-up
- Cost-effective clamping design
- Minimal set-up effort for different batch sizes and variants
- Autonomous manufacturing
- Can be easily automated with different loading and unloading systems
- Low-maintenance and durable

The profiles are precisely guided between two synchronized NC rotary axes, accurately positioned and firmly clamped

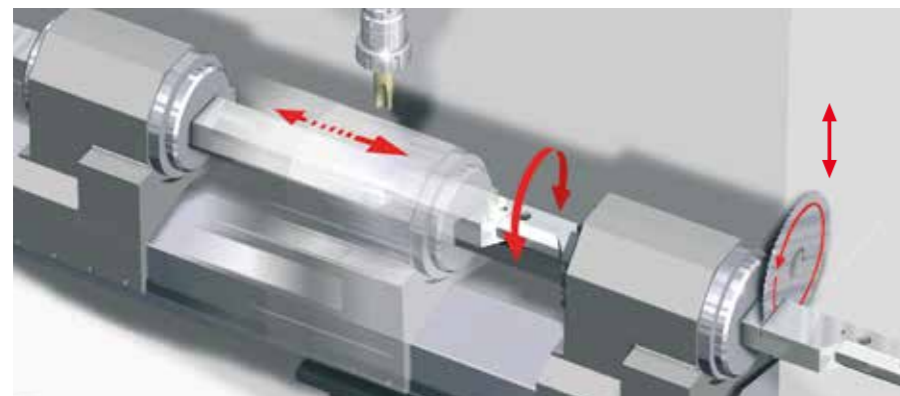

**FZ 08 S profile system:**  
Multifunctional machining center for the complete machining of workpieces with different lengths from extruded profiles. Whether milling, tapping, countersinking, reaming or cutting – everything is possible.



- Rectangular profiles
- Round profiles
- ▭ Flat profiles
- W W profiles
- C C profiles
- H H profiles
- T T profiles
- Z Z profiles
- U U profiles
- Customized profiles
- ...



# CHIRON TURNKEY

- Comprehensive process design
- Expert engineering
- Experienced project management
- Validation of statistical process capability
- Ensuring targeted productivity
- Production assistance during the initial phase
- Training in operation and programming
- CHIRON Service available around the world



## Turnkey customization completely from one source

Individual automation and engineered solutions for greater productivity

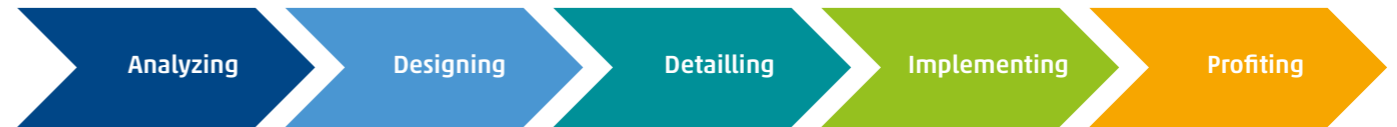

### Your advantages with CHIRON VariocellUno:

- Integrated automation in the smallest possible space (< 1 sq. meter)
- Machine and automation as a unit –no safety fence
- Simple installation and set-up, as well as in-plant repositioning
- High efficiency for more profit
- High storage capacity
- Simple operation and programming
- Raw and finished part pallets can be replaced during machining
- Double gripper robot for quick workpiece change (option)
- Integrated measuring part discharge (for instance SPC parts)
- Unrestricted access to the work area in the manual mode
- Robots can be used for additional tasks

Today, manufacturing excellent machining centers is not enough. Users expect a solution, which is as individual as it is intelligent. From one specific machining task, a „Turnkey process“ is to be developed around the workpiece based on the specifications and constraints. The CHIRON TURNKEY makes it possible to optimally solve complex tasks.

Together with perfectly adapted technology modules, CHIRON engineers create the most economical solution from one source to meet the customer’s special needs. This ensures decisive competitive advantages for CHIRON customers. CHIRON not only offers the machining solution itself, but also the support to keep manufacturing running at an optimal level.

### VariocellUno:

Flexible and inexpensive: a compact machining center, handling robot, workpiece storage and workpiece changing device (0°/180°) for loading and unloading during machining.

### Customized automation solutions:

- Machine-integrated spindle grippers
- Portal and articulated-arm solutions
- Load and unload devices
- Pallet changing systems
- Pallet storage for raw and finished parts
- Interlinked systems and much more

DZ 08 W and the robot cell VariocellUno as a unit: Transported together, no separate setup, robot cell alignment is not required. Integrated automation in the smallest possible space



# SmartLine

## The path to „Digitally enhanced machining“ is prepared

Intelligent machine control, digital networking, mutual machine communication, if „Digitally enhanced machining“ is mentioned, CHIRON may already has something to say. With the SmartLine program, the CHIRON Group provides a modular software system that enables customers to unlock the full potential of the digital manufacturing process.



**Machine**  
TouchLine, ProtectLine,  
ConditionLine



**Factory**  
DataLine, ProcessLine,  
ConditionLine



**Cloud**  
Remoteline,  
ConditionLine

### An overview of all modules

#### ConditionLine

- Constant monitoring and analysis of the machine condition
- Early detection of unusual operation behavior
- Customized degree of networking

#### ProtectLine

- Collision monitoring in all types of operation
- Preventative collision protection
- Safety during machining

#### TouchLine

- Context-sensitive information
- Machine-specific support
- User-guided operation

#### Remoteline

- Machine remote access
- Rapid assistance in event of fault
- Automatic notifications
- Optimum data security

#### DataLine

- Visualization of machine condition and process progress
- Configurable system
- Real-time information about all machinery

#### ProcessLine

- Digital twin and post-processor
- „Digital“ process run-in
- Collision-tested NC program

### User

Maintenance engineer  
Service

Machine operator  
Maintenance engineer

Machine operator  
Installer  
Maintenance engineer

Customer maintenance  
engineer  
Service

Production planner  
Head of manufacturing  
Controlling

Production planner



### CHIRON training courses and training are available for the following topics

- Service and maintenance
- Operation
- Programming
- Components
- Robot
- Customer-specific

# Trainings & workshops

## Ahead through qualification, because knowledge leads to success.

To enable you to use your CHIRON CNC machining center optimally, we offer a comprehensive range of qualification measures, training courses and training for operators, setup personnel and service technicians.

The training programme is characterised above all by flexibility in implementation. In addition to the courses in our CHIRON training centre, these can also take place at your location. Our trainers are able to offer courses in German and English. Optionally we offer further languages with the help of an translator.

In the CHIRON Training Center, we get interested persons, both beginners and pros, up-to-date with the latest technology, step by step. With a number of individually combinable machine courses and programming courses. In this way we qualify your employees while increasing the productivity of your CHIRON CNC machining center. This leads to more success for your company, since qualified and motivated employees are an important success factor.

Our training courses are designed didactically according to the latest teaching methods. By doing practical work in small groups, we take into account the field of interest and the level of knowledge of the participants. Our philosophy is to strongly qualify the participants through their own work on our training objects. Subsequently, what has been learned can be directly put into practice in routine work.



## Members of the CHIRON Group



**CHIRON Werke GmbH & Co. KG**  
Kreuzstraße 75  
78532 Tuttlingen, Germany  
[www.chiron.de](http://www.chiron.de)



**STAMA Maschinenfabrik GmbH**  
Siemensstraße 23  
73278 Schlierbach, Germany  
[www.stama.de](http://www.stama.de)



**SCHERER Feinbau GmbH**  
Marie-Curie-Straße 25  
63755 Alzenau, Germany  
[www.schererfeinbau.de](http://www.schererfeinbau.de)



**CMS-GmbH**  
Gewerbepark »take off« 125  
78579 Neuhausen o. E., Germany  
[www.cms-retrofit.de](http://www.cms-retrofit.de)

## CHIRON Group worldwide

FRANCE	Villeneuve-la-Garenne	CHINA	Beijing, Taicang
ITALY	Rodano Millepini	USA	Charlotte, Plymouth
POLAND	Paniówki	MEXICO	Querétaro
TURKEY	Istanbul	INDIA	Bangalore

## Representatives