

12 Series

Fast, compact single and double-spindle,
precision machining centers

chiron

www.chiron.de



FZ 12 W
Machining center with tool-changing device 0°/180°, enabling loading and unloading during machining.

Highly productive, compact and multifunctional

for the lowest cost per piece

The CHIRON 12 series machining centers are among the best machines in their class in terms of speed, compact construction and versatility of use. 12 series machining centers can be supplied as single-, double spindle or mill turn versions:

- Reliably high productivity
- Highest precision
- Minimum floor space requirements
- Fast set-up
- Simple operation
- High stability
- High dynamics
- Easy maintenance

Due to its modular design and numerous configuration possibilities, every 12 Series machine can be assembled into a perfect individualized solution.

Your benefits: Workpiece production at the lowest cost per piece with the lowest tolerances and excellent surface quality.

Synchronized production quality

with perfection down to the smallest detail

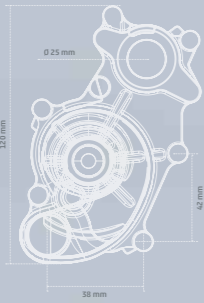

Automotive
Complete machining of integral components, such as casing covers for water pumps made of aluminum [120 mm x 55 mm x 60 mm]

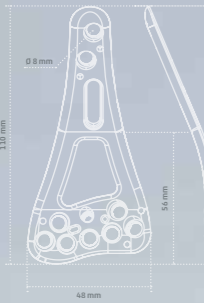

Medical Technology
Bone plate made of titanium [110 mm x 48 mm 1.5 mm]

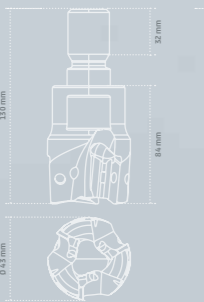

Tool Manufacturing
Milling, drilling, thread cutting and turning in one set-up for example, complex processing tools made of steel [130 mm x 43 mm]

We love perfection ...

That's why we view every detail as an exciting challenge. Whether automotive, aerospace, mechanical engineering, medical or precision engineering – the highquality machining centers of the CHIRON 12 Series reduce processing times, produce excellent surfaces and compress your manufacturing process into the smallest space possible. 12 series machining centers are the perfect tools to implement your product ideas quickly and with micron-level precision.

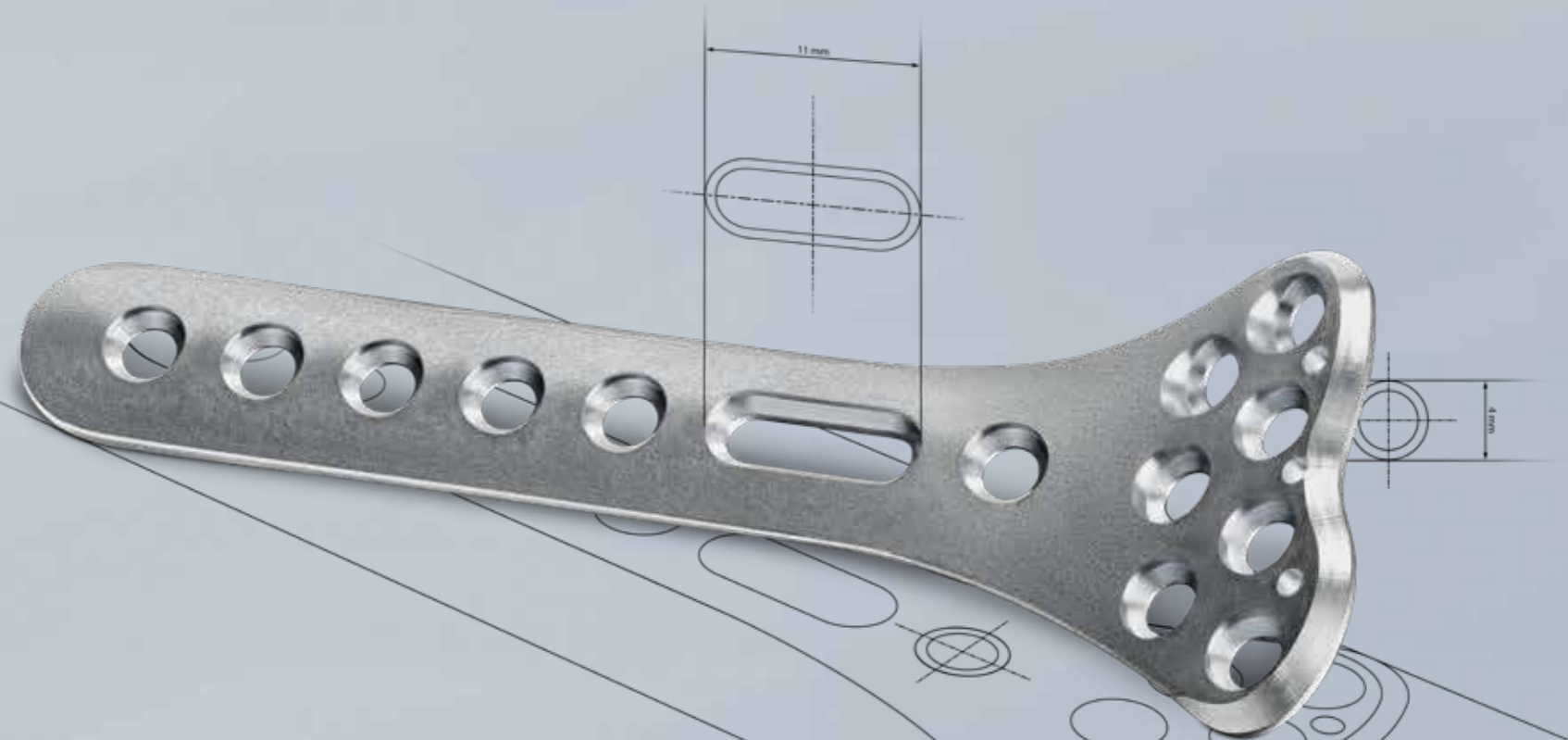

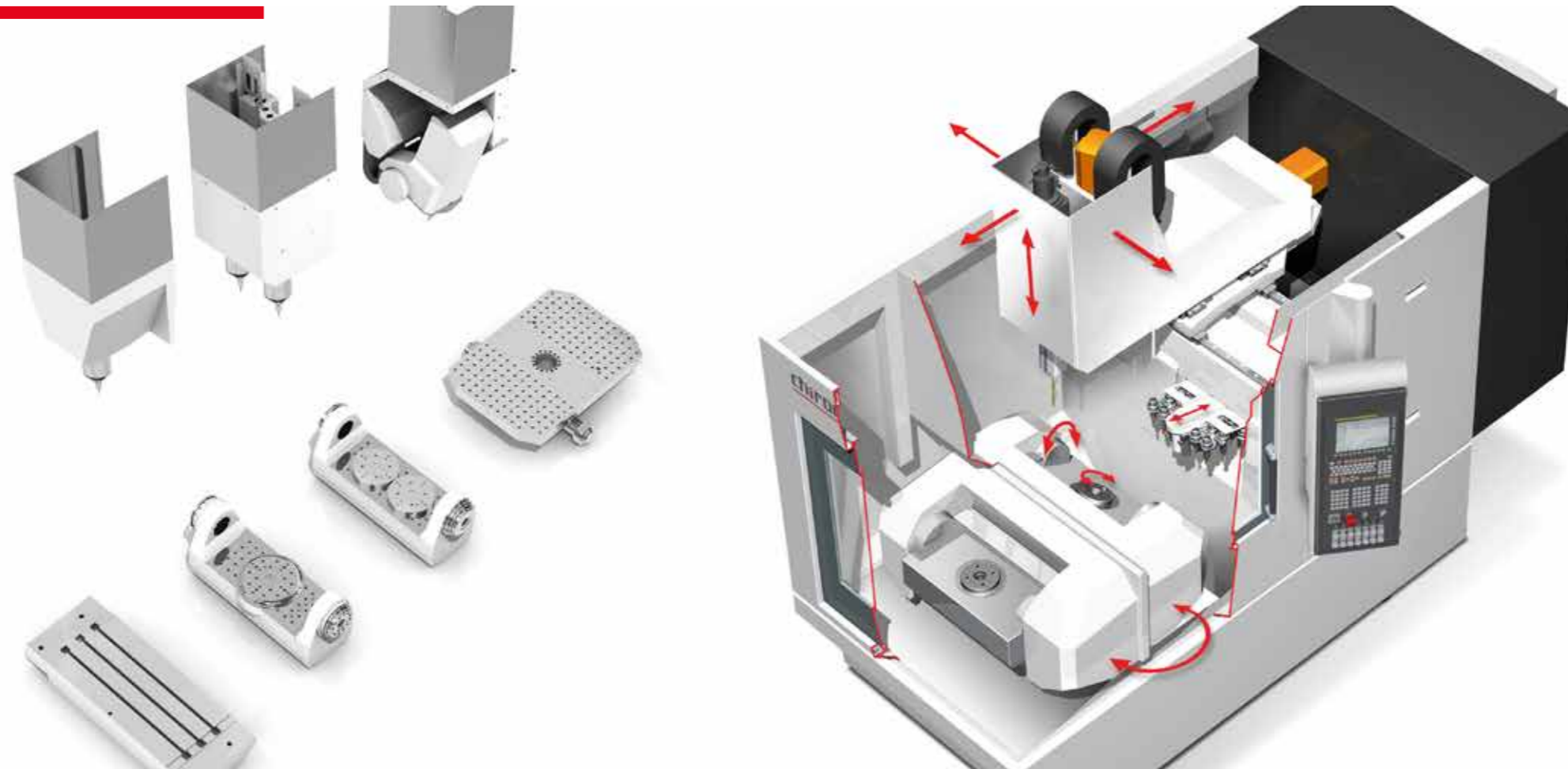

Compact and fast single-spindle machining center with integrated workpiece changing device 0°/180° for easy loading and unloading during machining.



Highest precision: Glass scales and digital drive technology allow high acceleration with equally high contour accuracy.



High-tech modules for any application

Perfectly balanced for greater flexibility

Modular concept:

- Vertical traveling column principle
- Compact installation area from width 1.490 mm x depth 3.200 mm
- Mineral cast machine bed
- High rigidity and thermal stability
- Motor spindles with water cooling
- Precision glass scales on all axes
- Dynamic direct drives and precision guides
- Robust CHIRON rotary axes
- Fully enclosed work area, stainless steel covers
- Smooth, steep walls for ideal chip flow directly into the chip conveyor
- Ergonomic operating and loading concept
- Service friendly access to all auxiliary units
- High durability, low maintenance

Spindles & spindle systems:

-  Proven single-spindle machining centers in the vertical traveling column design.
-  Highly productive double-spindle machining centers with spindle clearance 250 mm.
-  Machining centers with NC swivel head with infinitely programmable positioning in the range of -10° to +100°. Very robust, opposing pre-tensioned backlash-free precision gear with direct measuring system.

Tool changing systems:





-  Automatic tool change with the pick-up method (as fast 0.9 s) in single or double version for the provision of up to 128 tools (HSK 40 / HSK 50 / HSK 63).

Table options:

-  Fixed table with lots of space for devices or NC rotary table superstructures for multi-sided machining.
-  2-axis swivel rotary table with AC kinematics and one or two face plates (diameter: 1 x 280 / 2 x 245 mm) for single or multi-spindle multi-sided machining.
-  Workpiece changing device with table loading capacity of up to 300 kg per side and large clamping surfaces (2 x 660 x 350 mm), borehole pattern, central distributor for energy supplies.

The right machine for each component

Variants and extension options

Process advantages:

- Maximum path [X-Y-Z] 550-400-400 mm
- Maximum power 40 kW (40% ED)
- Spindle clearance DZ 250 mm
- Maximum spindle speed 30.000 rpm
- Chip-to-chip time starting 2,2 s
- Axis acceleration [X-Y-Z] max. 10 / 15 / 20 m/s²
- Rapid feed as fast as 75 m/min
- Number of tools max. 128
- Tool taper HSK 40 / HSK 50 / HSK 63
- Tool weight max. 5,0 kg
- Tool diameter max. 125 mm
- Tool length max. 250 mm
- Automatic workpiece change in 2,0 s



FZ 12 S five axis: Fast and compact precision machining center with a 2-axis swivel rotary table for 5-axis simultaneous and complete machining. Workpieces can be machined with high surface quality in one set-up.

DZ 12 S five axis: Fast and compact double-spindle machining center with 2-axis swivel rotary table and two face plates. 5-axis simultaneous operations are carried out using highperformance control options.

FZ 12 W: Machining center with automatic tool change using the pick-up method, and tool changing device (0°/180°) for loading and unloading during machining.

DZ 12 W: Double-spindle machining centre with automatic pick-up tool change and workpiece changing device (0°/180°) for parallel loading and unloading.

				S	FX	W	MT		
	FZ	CHAIN	FZ 12 S	FZ 12 S five axis	FZ 12 W				
	DZ	CHAIN	DZ 12 S	DZ 12 S five axis	DZ 12 W				
	S-HEAD	CHAIN	FZ 12 S				FZ12 mill turn		

Spindles & spindle systems
Automatic tool changer
Table options

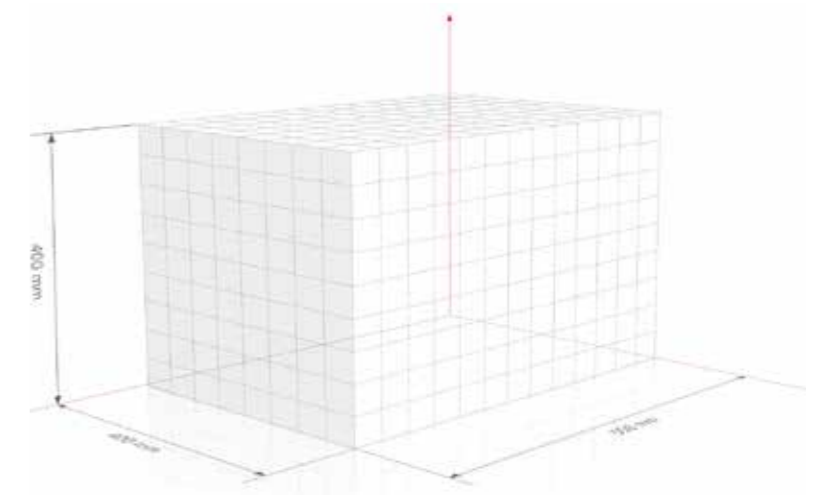

Flexible work areas and maximum paths
X=550, Y=400, Z=400 mm

Variety and flexibility as a foundation

Proven technology and the highest precision is our standard

Your advantages with the CHIRON fixed table or workpiece changing device:

- 3-axis basic machining center based on the vertical traveling column principle
- Compact installation area from width 1,490 mm x depth 3,200 mm (S) / 1,700 mm x 3,600 mm (W)
- Mineral cast machine bed
- High rigidity and thermal stability
- Clear, easily accessible work area
- Work area for larger workpieces or multiple set-ups
- Automatic tool change using the pick-up method
- Chip-to-chip time starting from 2.2 s
- Loading and unloading with tool changing device during machining (workpiece change time 2.0 s)
- Workpiece changing device with central splash guard and optimal accessibility
- Expandable to 4 axes with the basic device or to 5-axis machining with the 2-axis tilt rotary table
- Optional fully integrated automation solutions (VariocellUno)



FZ 12 S:
Compact and flexible precision machining center with fixed table and automatic tool change. A lot of space for devices or NC rotary table superstructures.

FZ 12 S:
Compact precision machining center with a fixed table and NC swivel head with infinitely programmable positioning (-10°/+100°).

FZ 12 W:
Machining center with automatic tool change using the pick-up method and tool changing device for loading and unloading during machining.

Workpiece changing device 0° / 180°
with ample space for devices and NC rotary tables, such as the installation of a workpiece swivel device as the fourth NC-axis.

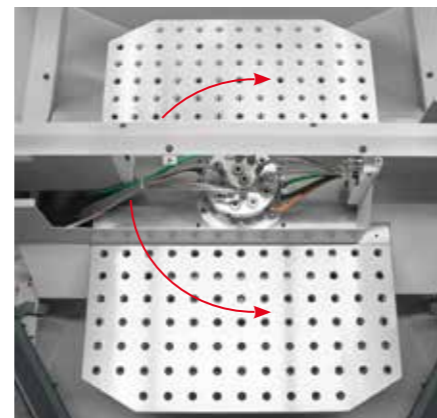

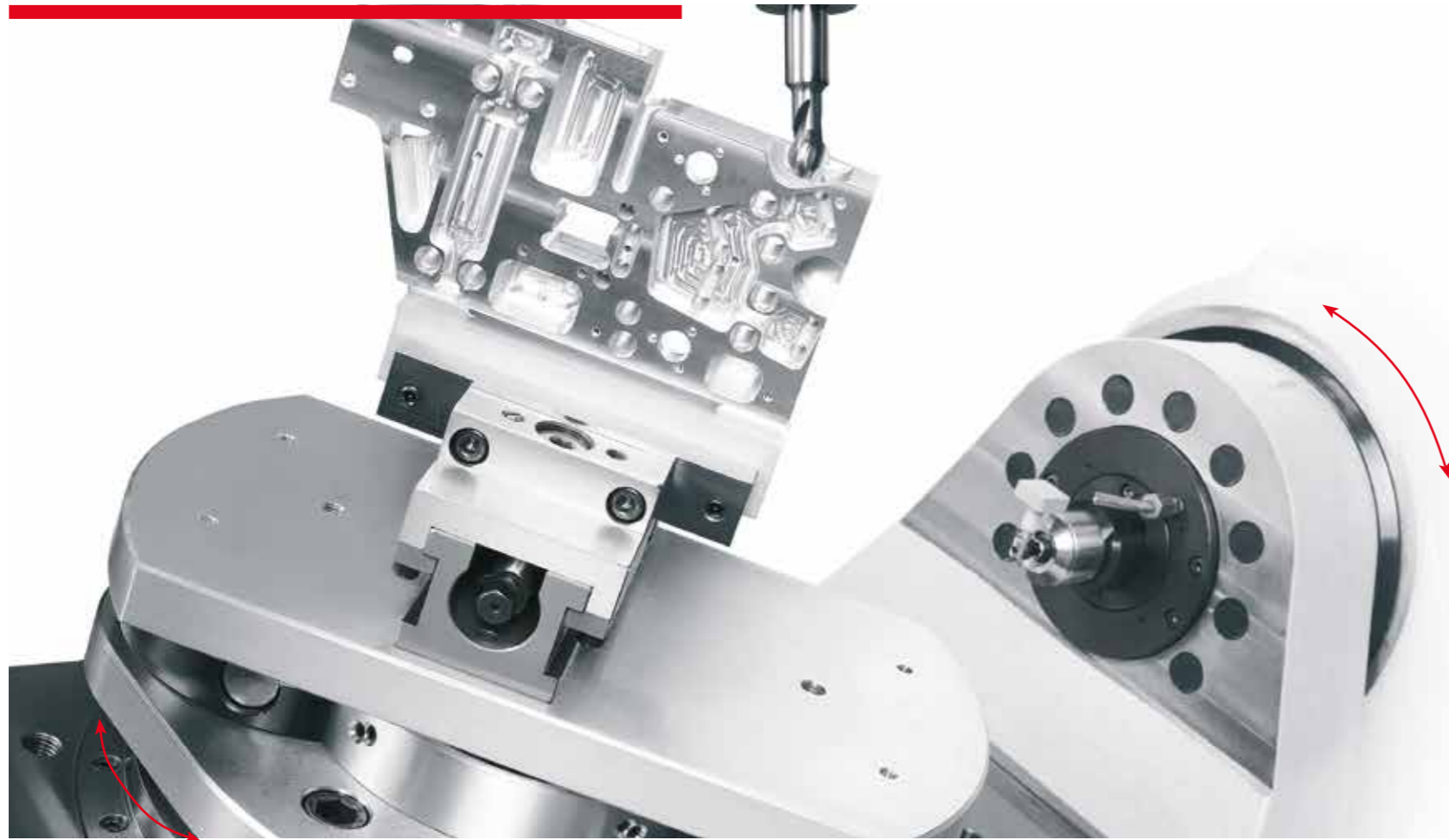

FZ 12 S five axis: Integrated CHIRON 2-axis rotary table, maintenancefree TORQUE drive technology and automatic tool change using the pick-up method.

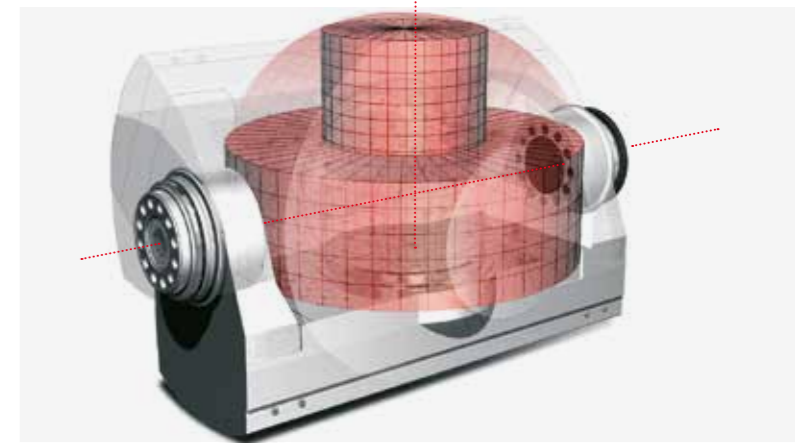

Five axis machining with the CHIRON rotary table program:
 - robust and reliable technology – developed and made by CHIRON
 - pre-tensioned, backlash-free precision gear with high overload capacity and high transmittable torque
 - turning option due to precise torque technology

Max. workpiece dimension (FZ12 FX)	swing diameter
Ø 280 x 385 mm	Ø 650 mm
up to Ø 610 x 200 mm	Ø 650 mm

Precision in one set-up

Complete machining with CHIRON five axis



DZ 12 S five axis:
 Doubled productivity with minimal space requirements: fast double-spindle machining center with a 2-axis swivel rotary table (AC-kinematics) for efficient complete machining with five simultaneously controlled axes.

Spindle clearance	250 mm
2-axis swivel rotary table CASD	280-2
- Swivel range	± 120°
- Face plates	2 x Ø 245 mm
Chain magazine / tool places	2 x 12 / 24 / 32 / 64
Tool change time	1,0 s

Your advantages with CHIRON five axis

- Compact installation area from width 2.100 mm x depth 3.200 mm
- Mineral cast machine bed
- High rigidity and thermal stability
- Highest precision in positioning and simultaneous operation
- CHIRON motor spindle speeds of up to 30,000 rpm
- Excellent surface quality
- Integrated CHIRON 2-axis swivel rotary table with direct measuring systems
- Integrated 6-way energy supply for clamping device on the face plate
- Zero-point clamping systems can be integrated
- Fourth axis with a pivoting range of up to +/- 120°
- 5th axis with TORQUE drive up to 1,000 rpm for turning work
- Automatic machine compensation due to the 3D touch probe TS27
- Vptional fully integrated automation solutions (VariocellUno)

Manufacture up to 75% faster

with CHIRON multi-spindle processing

Your advantages with CHIRON multi-spindle machining:

- Reduction of energy and space requirements
- Reduction of the total processing time
- Simplification of the material flow
- Reduced investment costs
- Reduced staff resources
- Water-cooled motor spindles up to 24,000 rpm
- Spindle clearance DZ 250 mm
- High rapid-feed speeds of up to 75 m/min
- Highest precision in positioning and simultaneous operation
- Precision glass scales on all axes
- Chip-to-chip time as fast as 2.2 s
- CHIRON 2-axis swivel rotary table possible
- Optional fully integrated automation solutions (VariocellUno)

The multiplier effect – more spindles, more cutting, more profit:

The combination of 2 spindles and a 4-fold clamping device results in a cost saving of up to 50%. Doubled productivity on one machine means a reduction of machining time of nearly 50%. There is also the option of multi-side machining through NC controlled rotary axis.

DZ 12 S / DZ 12 W:

Perfect combination of two spindles with workpiece changing device 0°/180°. (Figure: with NC rotary table and 4-fold clamping device for multi-sided machining).

DZ 12 five axis:

Very compact and fast double-spindle machining center with a 2-axis swivel rotary table (AC-kinematics) for the efficient 5-axis complete machining.





CHIRON TURNKEY

- Comprehensive process design
- Expert engineering
- Experienced project management
- Validation of statistical process capability
- Ensuring targeted productivity
- Production assistance during the initial phase
- Training in operation and programming
- CHIRON Service available around the world

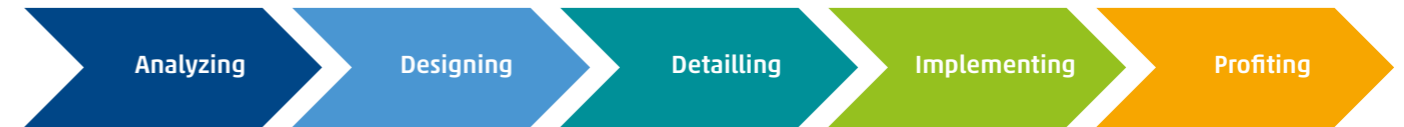

Turnkey customization completely from one source

Individual automation and engineered solutions for greater productivity

VariocellUno:

Flexible and inexpensive: a compact machining center, handling robot, workpiece storage and workpiece changing device (0°/180°) for loading and unloading during machining.

Machine and the robot cell VariocellUno as a unit: Transported together, no separate setup, robot cell alignment is not required. Integrated automation in the smallest possible space

Customized automation solutions:

- Machine-integrated spindle grippers
- Portal and articulated-arm solutions
- Load and unload devices
- Pallet changing systems
- Pallet storage for raw and finished parts
- Interlinked systems and much more

Your advantages with CHIRON VariocellUno:

- Integrated automation in the smallest possible space (< 1 sq. meter)
- Machine and automation as a unit –no safety fence
- Simple installation and set-up, as well as in-plant repositioning
- High efficiency for more profit
- High storage capacity
- Simple operation and programming
- Raw and finished part pallets can be replaced during machining
- Double gripper robot for quick workpiece change (option)
- Integrated measuring part discharge (for instance SPC parts)
- Unrestricted access to the work area in the manual mode
- Robots can be used for additional tasks

Today, manufacturing excellent machining centers is not enough. Users expect a solution, which is as individual as it is intelligent. From one specific machining task, a „Turnkey process“ is to be developed around the workpiece based on the specifications and constraints. The CHIRON TURNKEY makes it possible to optimally solve complex tasks.

Together with perfectly adapted technology modules, CHIRON engineers create the most economical solution from one source to meet the customer's special needs. This ensures decisive competitive advantages for CHIRON customers. CHIRON not only offers the machining solution itself, but also the support to keep manufacturing running at an optimal level.



SmartLine

The path to „Digitally enhanced machining“ is prepared

Intelligent machine control, digital networking, mutual machine communication, if „Digitally enhanced machining“ is mentioned, CHIRON may already has something to say. With the SmartLine program, the CHIRON Group provides a modular software system that enables customers to unlock the full potential of the digital manufacturing process.



Machine

TouchLine, ProtectLine, ConditionLine



Factory

DataLine, ProcessLine, ConditionLine



Cloud

Remoteline, ConditionLine

An overview of all modules

ConditionLine

- Constant monitoring and analysis of the machine condition
- Early detection of unusual operation behavior
- Customized degree of networking

ProtectLine

- Collision monitoring in all types of operation
- Preventative collision protection
- Safety during machining

TouchLine

- Context-sensitive information
- Machine-specific support
- User-guided operation

Remoteline

- Machine remote access
- Rapid assistance in event of fault
- Automatic notifications
- Optimum data security

DataLine

- Visualization of machine condition and process progress
- Configurable system
- Real-time information about all machinery

ProcessLine

- Digital twin and post-processor
- „Digital“ process run-in
- Collision-tested NC program

User

Maintenance engineer
Service

Machine operator
Maintenance engineer

Machine operator
Installer
Maintenance engineer

Customer maintenance
engineer
Service

Production planner
Head of manufacturing
Controlling

Production planner



Trainings & workshops

Ahead through qualification, because knowledge leads to success.

To enable you to use your CHIRON CNC machining center optimally, we offer a comprehensive range of qualification measures, training courses and training for operators, setup personnel and service technicians.

The training programme is characterised above all by flexibility in implementation. In addition to the courses in our CHIRON training centre, these can also take place at your location. Our trainers are able to offer courses in German and English. Optionally we offer further languages with the help of a translator.

In the CHIRON Training Center, we get interested persons, both beginners and pros, up-to-date with the latest technology, step by step. With a number of individually combinable machine courses and programming courses. In this way we qualify your employees while increasing the productivity of your CHIRON CNC machining center. This leads to more success for your company, since qualified and motivated employees are an important success factor.

Our training courses are designed didactically according to the latest teaching methods. By doing practical work in small groups, we take into account the field of interest and the level of knowledge of the participants. Our philosophy is to strongly qualify the participants through their own work on our training objects. Subsequently, what has been learned can be directly put into practice in routine work.

CHIRON training courses and training are available for the following topics

- Service and maintenance
- Operation
- Programming
- Components
- Robot
- Customer-specific



Members of the CHIRON Group



CHIRON Werke GmbH & Co. KG
Kreuzstraße 75
78532 Tuttlingen, Germany
www.chiron.de



STAMA Maschinenfabrik GmbH
Siemensstraße 23
73278 Schlierbach, Germany
www.stama.de



SCHERER Feinbau GmbH
Marie-Curie-Straße 25
63755 Alzenau, Germany
www.schererfeinbau.de



CMS-GmbH
Gewerbepark »take off« 125
78579 Neuhausen o. E., Germany
www.cms-retrofit.de

CHIRON Group worldwide

FRANCE	Villeneuve-la-Garenne	CHINA	Beijing, Taicang
ITALY	Rodano Millepini	USA	Charlotte, Plymouth
POLAND	Paniówki	MEXICO	Querétaro
TURKEY	Istanbul	INDIA	Bangalore

Representatives