

15 Series

Fast and powerful precision machining centers for profitable production - with one, two or four spindles

chiron

www.chiron.de



FZ 15 W
Machining center with basket tool changer (20 tool) and workpiece changing device 0°/180°
enabling loading and unloading during machining.

Productive, fast and compact

Leading-edge technology offering high reliability, performance and precision

CHIRON 15 series vertical machining centers are among the best machine tools in their class in terms of speed, dynamics, compact construction, stability and reliability. With ample power for great milling capacity, the CHIRON 15 series can be supplied as single, double, four-spindle or multi-profile versions, and are characterized by:

- Reliably high productivity
- Highest precision
- Minimum floor space requirements
- Fast set-up
- Simple operation
- High stability
- High dynamics
- Easy maintenance

Due to their modular structure and numerous configuration options, every basic machine of the 15 series can be combined to provide a perfectly customized solution. Your benefits: High precision and cutting capacity, as well as high machine availability and lower cost per piece.

Precision without compromise

Wide variety of workpieces – excellent surface quality

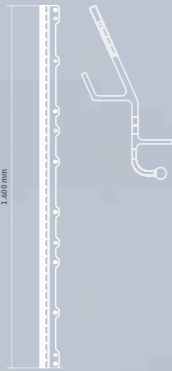

Aerospace
An example of 4-sided complete machining of extruded profiles with the CHIRON FZ15 MP, aluminum structured profile [1,600 mm x 75 mm]

We love perfection ...

That's why we view every detail as an exciting challenge. Whether automotive, aerospace, mechanical engineering, medical or precision engineering – the high-quality machining centers of the CHIRON 15 Series reduce processing times, produce excellent surfaces and compress your manufacturing process into the smallest space possible. The perfect tools to implement your product ideas quickly, with micron-level precision.

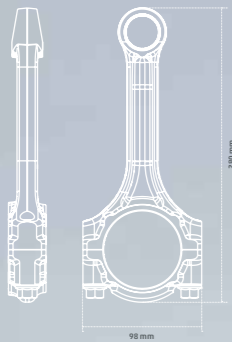

Automotive
Lowest cost-per-piece, complete machining of vehicle components such as: connecting rods and cylinders

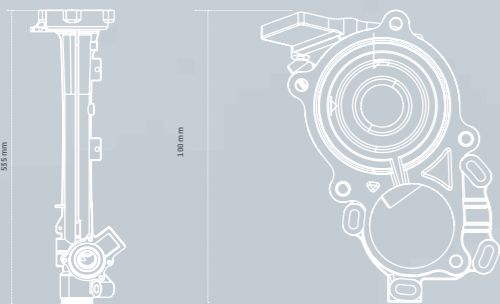

Automotive
e. g., machining of casing or steering boxes [535 x 100 x 100 mm]

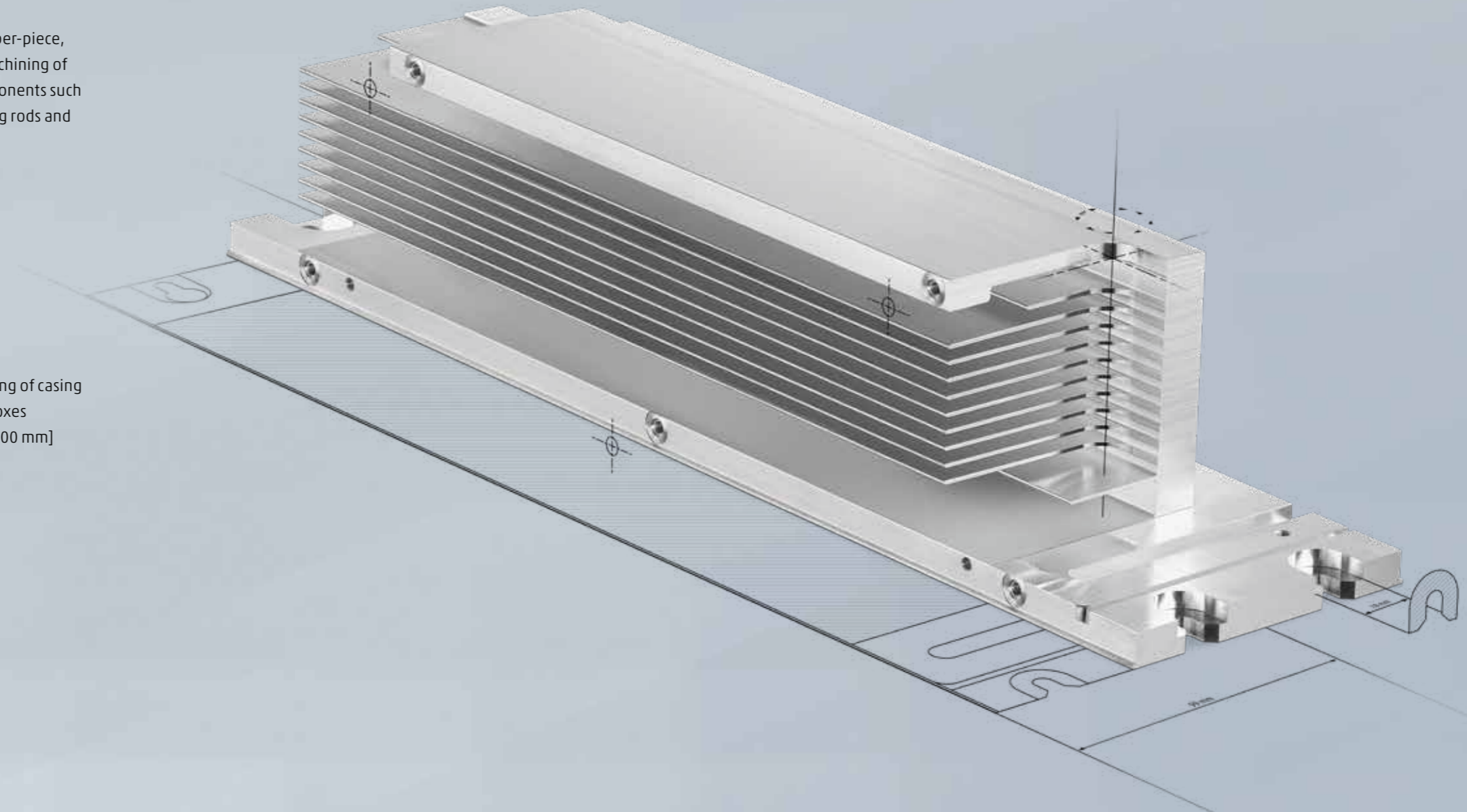

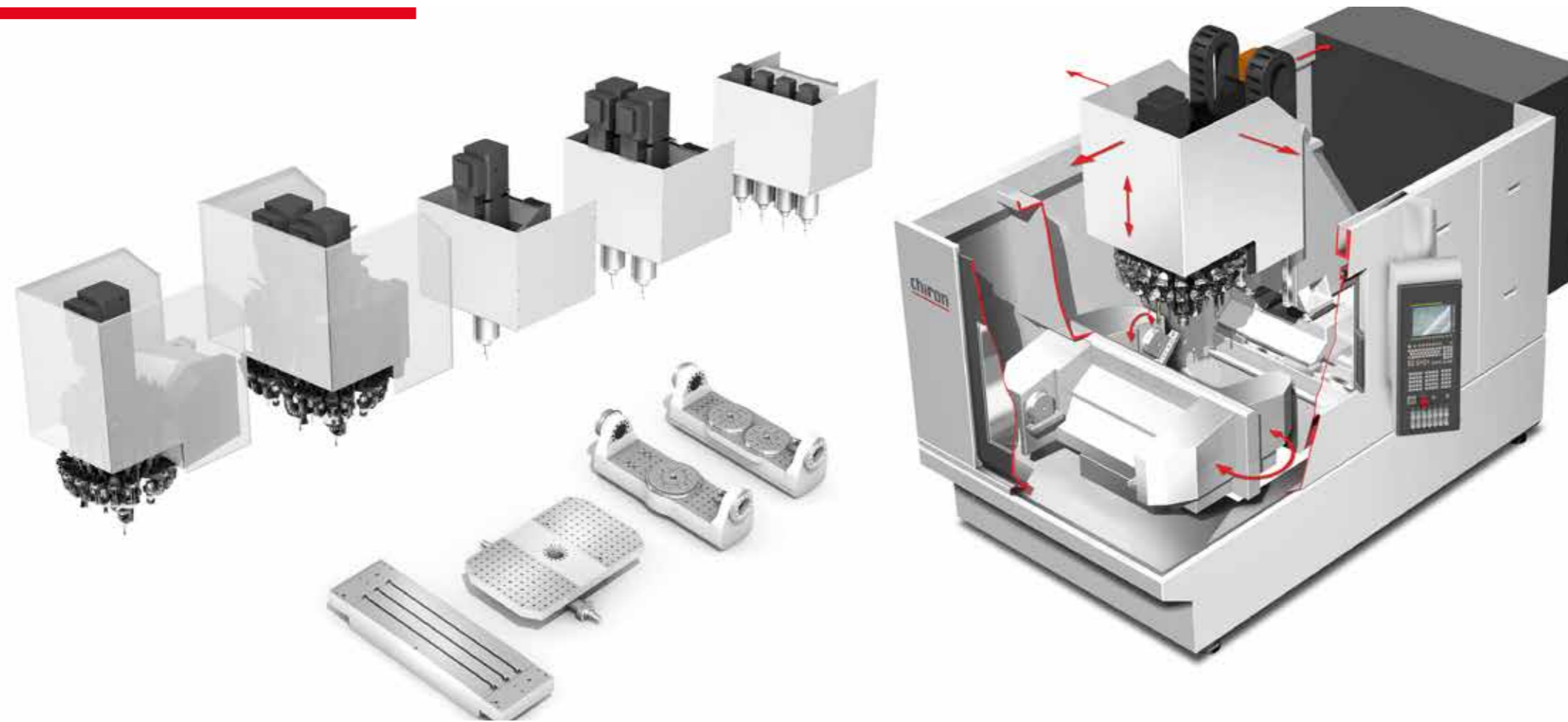

FZ 15 W: Compact, fast single-spindle machining center with integrated basket tool changer and integrated workpiece changing device 0°/180° for easy loading and unloading during machining.



Highest precision: Glass scales and digital drive technology allow high acceleration and contour accuracy.



CNC controls of the 15 series: Siemens, Fanuc



Versatility through high-tech modules

Perfectly suited to any application



Modular concept:

- Vertical traveling column principle
- Compact installation area from width 1,620 mm x depth 3,620 mm (W)
- Mineral cast machine bed
- High rigidity and thermal stability
- Precision glass scales on all axes
- Dynamic direct drives and precision guides
- Robust CHIRON rotary axes
- High running, positioning and long-term precision
- Fully enclosed work area, stainless steel covers
- Smooth, steep walls for ideal chip flow directly to the chip conveyor
- Ergonomic operating and loading concept
- Service friendly access to all auxiliary units
- High durability, low maintenance

Spindles & spindle systems:

-  Proven single-spindle machining center in a vertical traveling column design
-  Highly productive double-spindle machining centers with a spindle clearance of 250, 320 or 400 mm
-  Highly productive four-spindle machining centers with a spindle clearance of 3 x 200 mm



Tool changing systems:

-  CHIRON basket tool changer with 20 (2 x 12 for double-spindle machines) tool places (SK 40 or HSK 63). High productivity due to chip-to-chip times as short as 1.7 s.
-  Automatic tool change using the pick-up method from 0.9 s for 48/64 tool places (DZ 2 x 24/32 / TZ 4 x 14), HSK 63.



Background magazine for the provision of up to 158 tools during machining.

Table options:

-  Fixed table with plenty of space for various devices or NC rotary table assemblies for multi-sided machining.
-  2-axis swivel rotary table with one or two face plates (Ø 1 x 280 / 2 x 280 mm) for single- or double-spindle multi-sided machining.
-  Workpiece changing device with table loading up to 400 kg per side and large clamping surfaces up to 2 x 940 x 470 mm, borehole pattern, central distribution for power supply lines.

The right machine for each component

Proven modules for customized configurations

Process advantages:

- Maximum path [X-Y-Z] 730-400-425 mm
- Maximum power 58 kW (30% ED)
- Spindles / clearance DZ 2 / 250 or 320 mm
- Spindles / clearance TZ 4 / 200 mm
- Maximum spindle speed 20.000 rpm
- Chip-to-chip time from 1,9 s
- Axis acceleration X-Y-Z max. 12 / 12 / 12 m/s²
- Rapid feed as fast as. 75 m/min
- Max. number of tools 158
- Tool taper SK 40 / HSK 63
- Maximum tool weight 10,0 kg
- Maximum tool diameter 175 mm
- Max. tool length 300 mm
- Automatic workpiece change from 3,5 s



FZ 15 S five axis: Fast precision machining center with a basket tool changer and a 2-axis swivel rotary table for 5-axis simultaneous and complete machining. Workpieces can be machined with high surface quality in one set-up.

DZ 15 S five axis: Highly productive double-spindle machining center with a 2-axis swivel rotary table and two face plates. 5-axis simultaneous operations are carried out using highperformance control options

DZ 15 W: Highly productive double-spindle machining center with a fast basket tool changer (2 x 12 tool places) and workpiece changing device for loading and unloading during machining.

FZ 15 S profile system: Multifunctional machining center for the complete machining of workpieces of different lengths from extruded profiles. Whether milling, tapping, countersinking, reaming or cutting – everything is possible

		Spindles & spindle systems			
		Automatic tool changer		Table options	
		S	FX	W	MP
FZ	BASKET	FZ 15 S	FZ 15 S five axis	FZ 15 W	FZ 15 S profile system
FZ	CHAIN	FZ 15 S	FZ 15 S five axis	FZ 15 W	
DZ	BASKET	DZ 15 S	DZ 15 S five axis	DZ 15 W	
DZ	CHAIN	DZ 15 S	DZ 15 S five axis	DZ 15 W	
TZ	CHAIN			TZ 15 W	

Flexible work areas and maximum paths:
X=730, Y=400, Z=425 mm

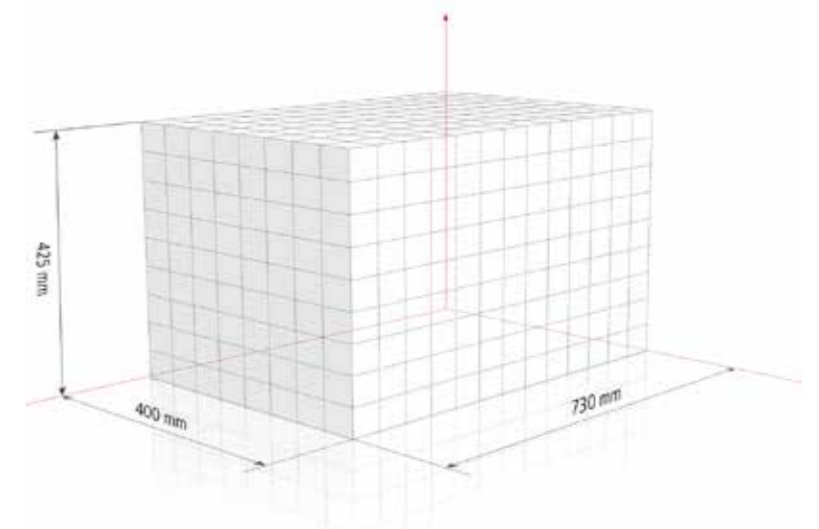

Diversity and flexibility

Reliable technology and high precision as a foundation

Your advantages with the CHIRON fixed table or workpiece changing device:

- 3-axis machining center based on the vertical traveling column principle
- Expandable to four axes with the basic device or 5-axis machining with 2-axis swivel rotary table (IWW)
- Mineral cast machine bed
- High rigidity and thermal stability
- Clear, easily accessible work area
- Work area for larger workpieces or multiple set-ups
- Chip-to-chip time starting from 1.7 s
- Loading and unloading with workpiece changing device during machining (workpiece change time starting from 2.4 s)
- Workpiece changing device with central splash guard and optimal accessibility
- High table loading
- Optional fully integrated automation solutions (VariocellUno)

Workpiece changing device 0 / 180°

The workpiece changing device is equipped with a central distribution for power supply lines and provides ample space for various devices or NC rotary table assemblies. Downtimes are greatly reduced due to loading and unloading during machining.

The integrated workpiece changing device can be configured as desired by the customer with a swivel plate for individual set-ups. There is also the option of integrating one or two 2-axis swivel rotary tables for 5-axis machining.

FZ 15 S:

Flexible precision machining center with the fast basket tool changer. The fixed table provides ample space for various devices or NC rotary table assemblies.

FZ 15 W:

Fast precision machining center with automatic pick-up tool changer and workpiece changing device for loading and unloading during machining.

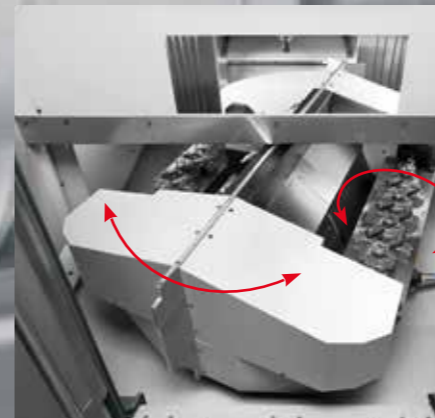
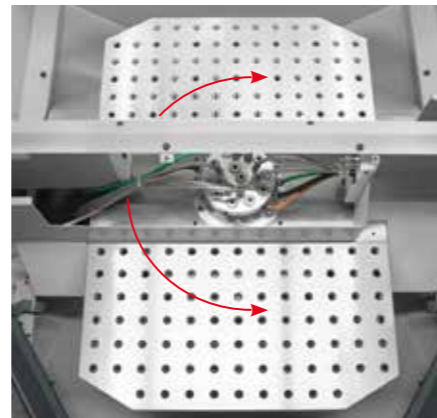

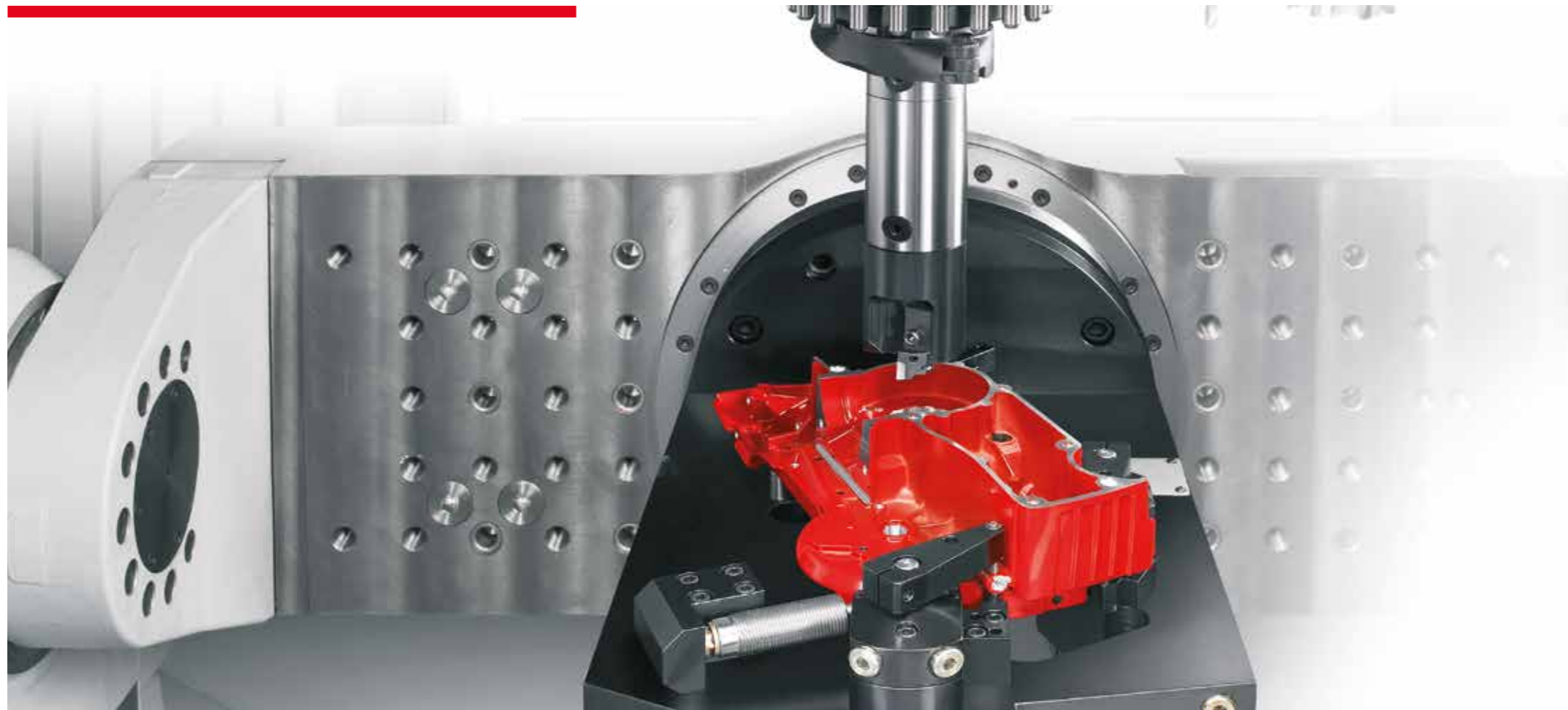

FZ 15 S five axis: Fast precision machining center with the fast CHIRON basket tool changer and a 2-axis swivel rotary table. High productivity, with chip-to-chip times as short as 1.7 seconds and tool changing times from 0.9 seconds.



DZ 15 S five axis: Doubled productivity with minimal space requirements: fast double-spindle machining center with a 2-axis swivel rotary table with two face plates for efficient complete machining with five simultaneously controlled axes.

Five-axis machining with the CHIRON rotary table program:

- Solid and reliable technology - developed and manufactured by CHIRON
- Backlash-free preclamped precision gears with high overload capacity and large holding torque
- Rotation option due to high-precision torque drives

Precision and dynamics at the highest level

Complete machining with CHIRON five axis

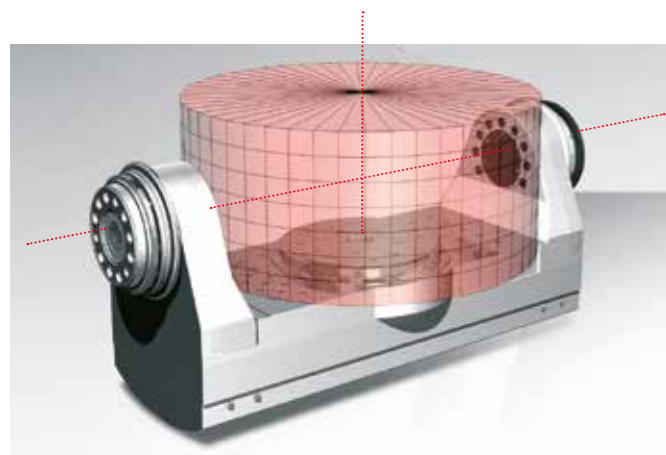

The workpiece is positioned exactly in the center of the swivel axes, which minimizes compensating movements of the linear axes. The unique CHIRON basket tool changer allows extremely short cycle times. Combined with fast rapid feeds and the dynamic NC swivel rotary tables, non-productive times are reduced to a minimum.

	FZ 15 S five axis	DZ 15 S five axis
Maximum workpiece dimensions	Ø 700 x 425 mm	2 x 320 x 425 mm
Interference range	Ø 650 mm	Ø 650 mm
Spindle clearance (DZ)		250 / 320 / 400 mm
2-axis swivel rotary table CASD	280	280-2
- Swivel range	± 120°	± 120°
- Face plate (n)	Ø 280 mm	2 x Ø 280 mm
- Borehole pattern	M 16 x Ø 15H7 x 50 mm	M 16 x Ø 15H7 x 50 mm
Tool places basket / chain	20 / 48 - 158	2 x 12 / 2 x 24 - 2 x 104
Tool change time	0,9 s	0,9 s

Your advantages with CHIRON five axis

- Highest precision in positioning and simultaneous operation
- High rigidity and thermal stability
- Mineral cast machine bed
- Spindle speed up to 20,000 rpm
- Excellent surface quality
- Integrated CHIRON 2-axis swivel rotary table with direct measuring systems
- Integrated 6-way energy supply for clamping device on the face plate
- Zero-point clamping systems can be integrated
- Fourth axis with a pivoting range of up to +/- 120°
- 5th axis with torque drive up to 1,000 rpm for turning work
- Automatic machine compensation due to the 3D touch probe TS27
- Optional fully integrated automation solutions (VariocellUno)

Manufacture up to 75% faster

Increase profits with 2 or 4 spindles

Your advantages with CHIRON multi-spindle machining:

- Reduction of energy and space requirements
- Reduction of total processing time
- Simplification of material flow
- Reduced investment costs
- Reduced staff resources
- Water-cooled motor spindles up to 20,000 rpm
- Highest productivity with 2 or 4 spindles
- High rapid-feed speeds of up to 75 m/min
- Highest precision in positioning and simultaneous operation
- Precision glass scales on all axes
- Chip-to-chip time starting from 1.7 s
- CHIRON 2-axis swivel rotary table optional
- Optional fully integrated automation solutions (VariocellUno)

The multiplier effect – more spindles, more cutting, more profit:

Doubled productivity on one machine means a reduction in machining time of nearly 50%. There is also the option of multi-sided machining using an NC-controlled rotary axis.

DZ 15 W:

A perfect combination of two spindles with a fixed table or workpiece changing device 0°/180°: (Figure: with an NC rotary table and a quadruple clamping device for multi-sided machining)

TZ 15 S five axis:

An economical combination of four high-performance spindles and workpiece changing device. (Figure: with an NC rotary table and a quadruple clamping device for multi-sided machining)



DZ 15 S five axis:

The combination of two spindles and a fixed table, or workpiece changing device 0°/180°, as well as a quadruple clamping device results in cost savings of up to 50%. (Figure: with the CHIRON basket tool changer)



Multifunctional by the meter

Complete machining of extruded profiles with the CHIRON profile system

Your advantages with CHIRON profile system:

- Automatic production of consecutive workpieces
- Profile sizes up to 150 x 150 mm
- Lower costs per unit due to high productivity of the process
- Spindle speeds up to 20,000 rpm
- High production quality by machining in one set-up
- Cost-effective clamping design
- Minimal set-up effort for different batch sizes and variants
- Quick retooling for manufacturing variants
- Autonomous manufacturing
- Can be easily automated with different loading and unloading systems
- High durability, low maintenance

FZ 15 S profile system:

Multifunctional machining center for the complete machining of workpieces of different lengths from extruded profiles of any type. Milling, drilling, threading, countersinking, reaming or separating – anything is possible, regardless of whether series parts or variants are being machined.

With the machining center FZ15 profile system, you can process workpieces of any length directly from the extruded profile – continuously and completely. The profiles are precisely guided between two synchronized NC rotary axes, accurately positioned and firmly clamped. The raw material is automatically advanced by the feed unit. The workpiece is discharged via a practical unloader.

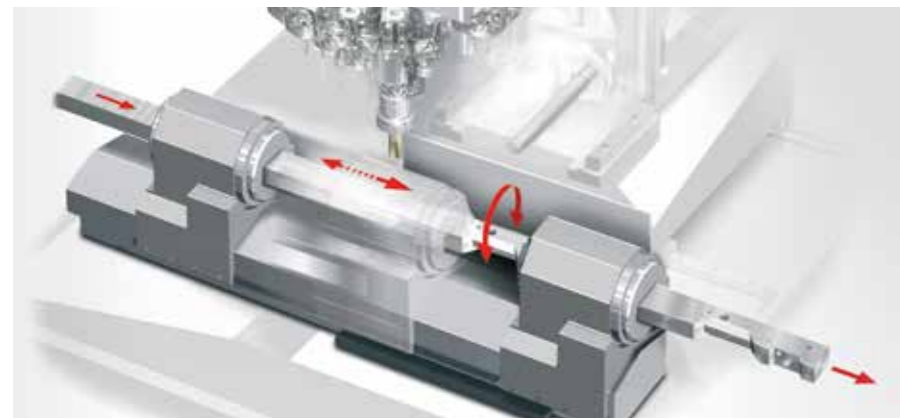

- Rectangular profiles
- Round profiles
- ▭ Flat profiles
- W W profiles
- C C profiles
- H H profiles
- T T profiles
- Z Z profiles
- U U profiles
- Customized profiles
- ...

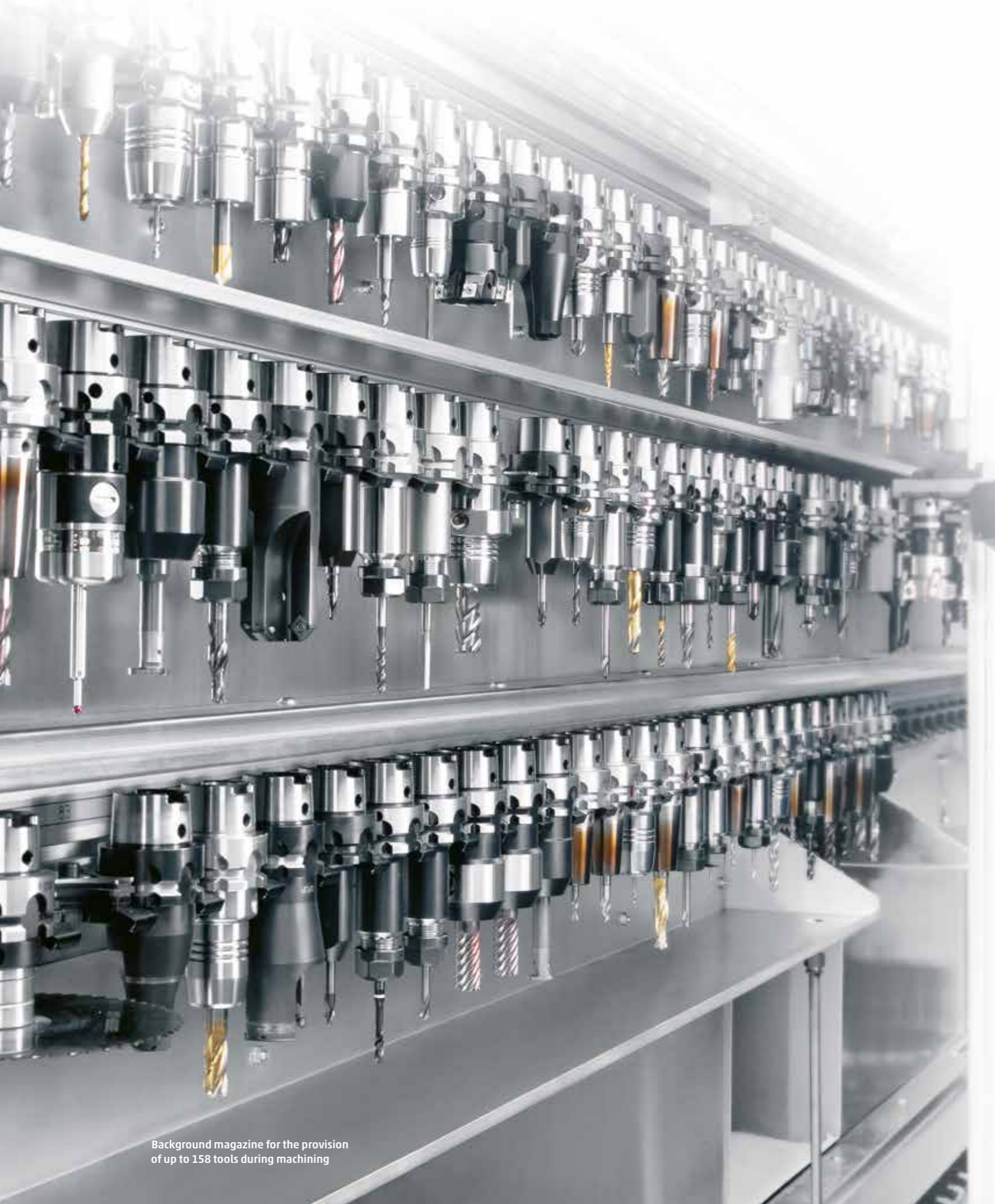

Background magazine for the provision of up to 158 tools during machining

Options for your production

individualized to meet your specific requirements

Series 15 – further options:

- High Speed Plus package
- Reinforced spindle drive
- Work area suctioning unit
- Connection for central suctioning unit
- Energy-efficiency package with an intelligent energy-saving control
- Automatic doors
- Zero point clamping systems
- Oil package with fire-extinguishing system
- Background magazine with a shelf construction
- Robot interface and much more

Internal cooling via the spindle up to 70 bar; also available with a frequencycontrolled pump



Stationary 3D probing system TS 27 for tool length measurement, tool breakage checks as well as machine compensation.



CHIRON laser control for tool breakage checks, for tool measurement and for machine compensation.



Workpiece gripper in the main spindle for machine-integrated workpiece handling



CHIRON TURNKEY

- Comprehensive process design
- Expert engineering
- Experienced project management
- Validation of statistical process capability
- Ensuring targeted productivity
- Production assistance during the initial phase
- Training in operation and programming
- CHIRON Service available around the world



Turnkey customization completely from one source

Individual automation and engineered solutions for greater productivity

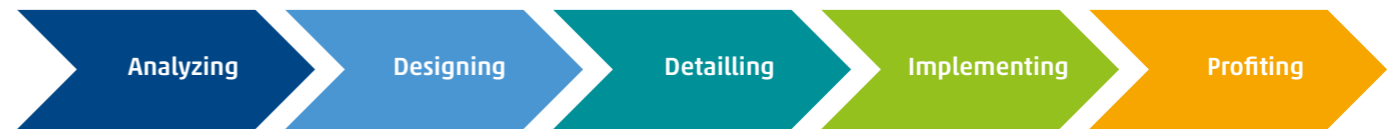

Your advantages with CHIRON VariocellUno:

- Integrated automation in the smallest possible space (< 1 sq. meter)
- Machine and automation as a unit –no safety fence
- Simple installation and set-up, as well as in-plant repositioning
- High efficiency for more profit
- High storage capacity
- Simple operation and programming
- Raw and finished part pallets can be replaced during machining
- Double gripper robot for quick workpiece change (option)
- Integrated measuring part discharge (for instance SPC parts)
- Unrestricted access to the work area in the manual mode
- Robots can be used for additional tasks

Today, manufacturing excellent machining centers is not enough. Users expect a solution, which is as individual as it is intelligent. From one specific machining task, a „Turnkey process“ is to be developed around the workpiece based on the specifications and constraints. The CHIRON TURNKEY makes it possible to optimally solve complex tasks.

Together with perfectly adapted technology modules, CHIRON engineers create the most economical solution from one source to meet the customer’s special needs. This ensures decisive competitive advantages for CHIRON customers. CHIRON not only offers the machining solution itself, but also the support to keep manufacturing running at an optimal level.

VariocellUno:

Flexible and inexpensive: a compact machining center, handling robot, workpiece storage and workpiece changing device (0°/180°) for loading and unloading during machining.

Customized automation solutions:

- Machine-integrated spindle grippers
- Portal and articulated-arm solutions
- Load and unload devices
- Pallet changing systems
- Pallet storage for raw and finished parts
- Interlinked systems and much more

Machine and the robot cell VariocellUno as a unit: Transported together, no separate setup, robot cell alignment is not required. Integrated automation in the smallest possible space



SmartLine

The path to „Digitally enhanced machining“ is prepared

Intelligent machine control, digital networking, mutual machine communication, if „Digitally enhanced machining“ is mentioned, CHIRON may already has something to say. With the SmartLine program, the CHIRON Group provides a modular software system that enables customers to unlock the full potential of the digital manufacturing process.



Machine
TouchLine, ProtectLine,
ConditionLine



Factory
DataLine, ProcessLine,
ConditionLine



Cloud
Remoteline,
ConditionLine

An overview of all modules

ConditionLine

- Constant monitoring and analysis of the machine condition
- Early detection of unusual operation behavior
- Customized degree of networking

ProtectLine

- Collision monitoring in all types of operation
- Preventative collision protection
- Safety during machining

TouchLine

- Context-sensitive information
- Machine-specific support
- User-guided operation

Remoteline

- Machine remote access
- Rapid assistance in event of fault
- Automatic notifications
- Optimum data security

DataLine

- Visualization of machine condition and process progress
- Configurable system
- Real-time information about all machinery

ProcessLine

- Digital twin and post-processor
- „Digital“ process run-in
- Collision-tested NC program

User

Maintenance engineer
Service

Machine operator
Maintenance engineer

Machine operator
Installer
Maintenance engineer

Customer maintenance
engineer
Service

Production planner
Head of manufacturing
Controlling

Production planner



CHIRON training courses and training are available for the following topics

- Service and maintenance
- Operation
- Programming
- Components
- Robot
- Customer-specific

Trainings & workshops

Ahead through qualification, because knowledge leads to success.

To enable you to use your CHIRON CNC machining center optimally, we offer a comprehensive range of qualification measures, training courses and training for operators, setup personnel and service technicians.

The training programme is characterised above all by flexibility in implementation. In addition to the courses in our CHIRON training centre, these can also take place at your location. Our trainers are able to offer courses in German and English. Optionally we offer further languages with the help of an translator.

In the CHIRON Training Center, we get interested persons, both beginners and pros, up-to-date with the latest technology, step by step. With a number of individually combinable machine courses and programming courses. In this way we qualify your employees while increasing the productivity of your CHIRON CNC machining center. This leads to more success for your company, since qualified and motivated employees are an important success factor.

Our training courses are designed didactically according to the latest teaching methods. By doing practical work in small groups, we take into account the field of interest and the level of knowledge of the participants. Our philosophy is to strongly qualify the participants through their own work on our training objects. Subsequently, what has been learned can be directly put into practice in routine work.



■ Members of the CHIRON Group



CHIRON Werke GmbH & Co. KG
Kreuzstraße 75
78532 Tuttlingen, Germany
www.chiron.de



STAMA Maschinenfabrik GmbH
Siemensstraße 23
73278 Schlierbach, Germany
www.stama.de



SCHERER Feinbau GmbH
Marie-Curie-Straße 25
63755 Alzenau, Germany
www.schererfeinbau.de



CMS-GmbH
Gewerbepark »take off« 125
78579 Neuhausen o. E., Germany
www.cms-retrofit.de

■ CHIRON Group worldwide

FRANCE	Villeneuve-la-Garenne	CHINA	Beijing, Taicang
ITALY	Rodano Millepini	USA	Charlotte, Plymouth
POLAND	Paniówki	MEXICO	Querétaro
TURKEY	Istanbul	INDIA	Bangalore

■ Representatives