

16 Series

Dynamic, highly precise machining centers for high-performance and productive machining of complex workpieces

chiron

www.chiron.de



Highly productive double-spindle machining center DZ 16 W with workpiece changing device and intuitive TouchLine operating system, a task-oriented and context-sensitive user interface.

The new 16 series - Visionary precision

Productive manufacturing with highest accuracy

Developed and driven by the demands of leading manufacturers, the new CHIRON FZ/DZ 16 combines the highest levels of precision, dynamics and cutting capabilities. Intensive dialog within multiple market segments has resulted in a fundamentally new machining platform with mobile gantry design - achieving unmatched surfaces on increasingly complex workpieces. Maximum productivity, precision and flexibility are no longer contradictions.

- Reliably high productivity
- Highest precision and processing quality
- Low space requirement
- Fast set-up
- Simple operation
- High stability
- High dynamics
- Easy maintenance

Precision without compromise

Large variety of workpieces - excellent surface quality

We love perfection ...

That's why we view every detail as an exciting challenge. Whether automotive, aerospace, mechanical engineering, medical or precision engineering – the high quality machining centers of the CHIRON 16 Series reduce processing times, produce with high milling capacity and compress your manufacturing process into the smallest space possible. The perfect tools to implement your product ideas quickly, with micron-level precision.

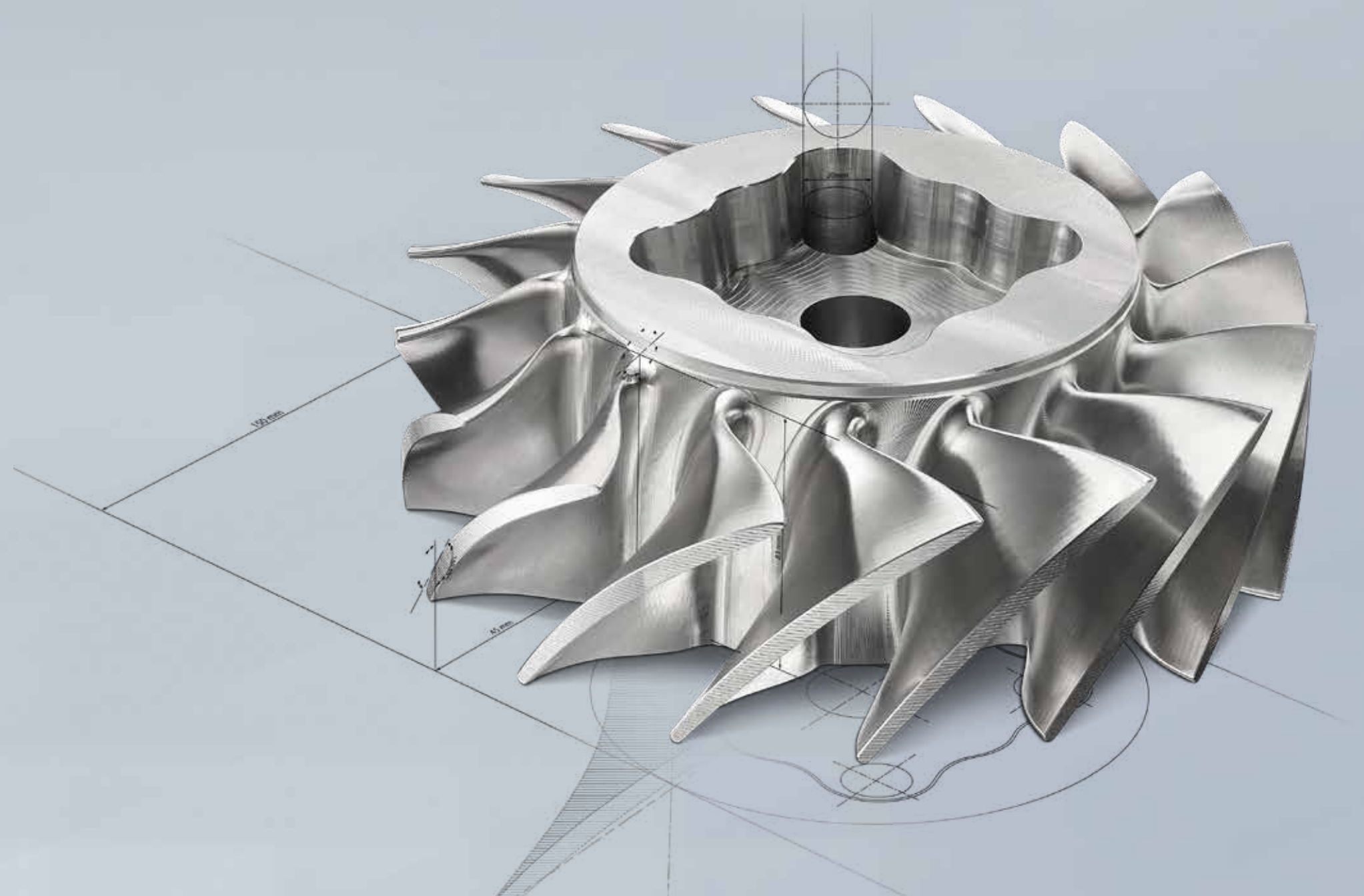

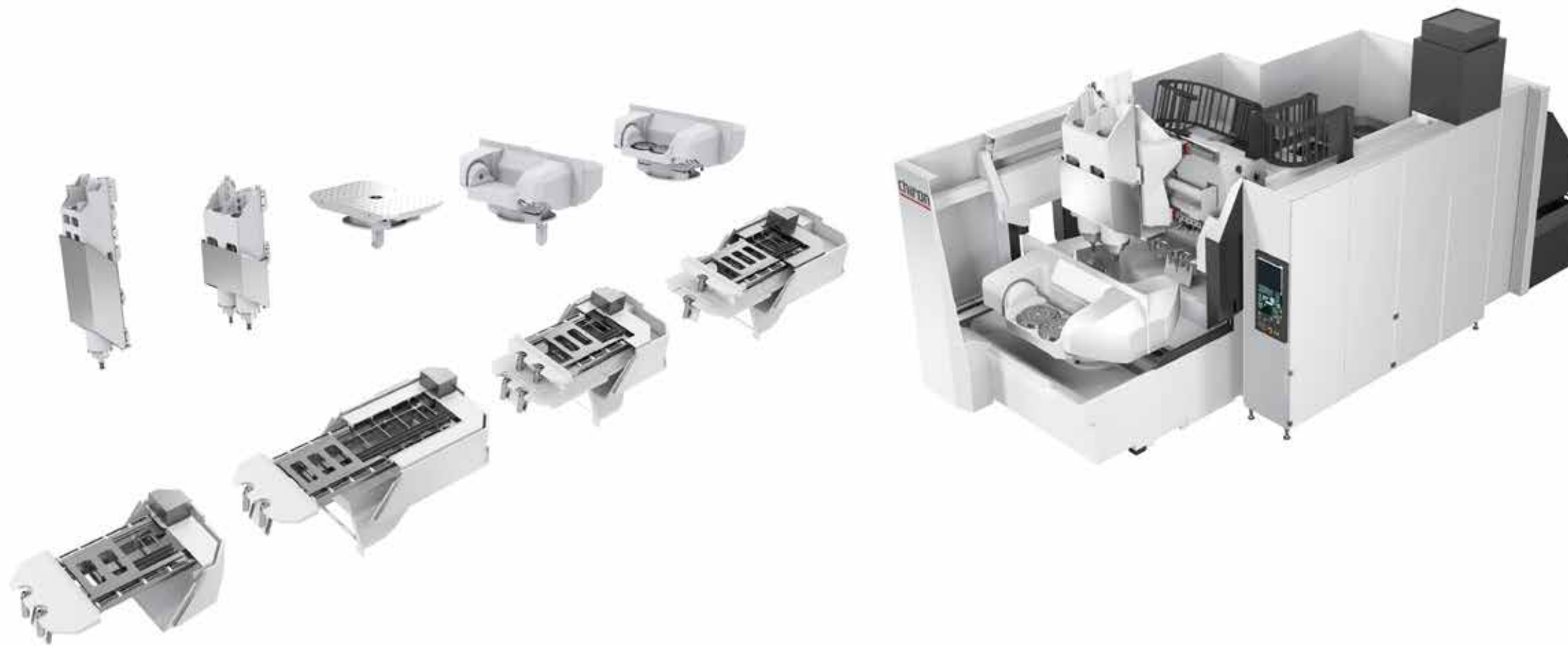

Intuitive and context-sensitive TouchLine operating system



High variability due to high-tech modules

Perfectly matched for every application

Modular concept:

- Mobile gantry design
- Small footprint even with a large number of tools
- Mineral casting machine bed, inherently stiff and vibration-damping
- High static and dynamic stiffness
- Excellent thermal stability
- Highly productive motor spindles
- Rotary axes with torque direct drive
- Actively cooled drive components
- Ideal chip flow through hanging cradle and steeply sloping walls
- Loading and unloading of tools during machining
- Context-sensitive and intuitive TouchLine operating system
- Condition monitoring at the control panel via IO-Link and ProfiNet
- Service-friendly accessibility to all components



Spindeln und Spindelsysteme:

-  Proven single-spindle machining center in a vertical traveling column design
-  Highly productive double-spindle machining centers with a spindle clearance of 320 mm

Werkzeugwechselsysteme:

-  Automatic tool change using the pick-up method from 2,5 s with 42/60/90/162 tools (DZ 2 x 28/44/64/80).

Tischvarianten:

-  Swivel rotary table in A & A-C kinematics with one or two face plates (Ø 1x 450 mm / 2x 319 mm) for single or double-spindle machining.
-  Workpiece changing device with table loading up to 750 kg per side and large clamping surfaces up to 2x 900 x 500 mm, borehole pattern, central distributor for energy supply.
-  Integrated workpiece changer in A & A-C kinematics with one or two face plates (Ø 1x 319 mm / 2x 319 mm) for single or double-spindle machining.

The right machine for each component

Proven modules for customized configurations

Process advantages

FZ 16 S five axis

DZ 16 W

— Travel X-Y-Z max.	660-660-400 mm	340-450-400 mm
— Power max.	61 kW	61 kW
— Spindle distance DZ		320 mm
— Spindle speed max.	20.000 rpm	20.000 rpm
— Torque max.	200 Nm	200 Nm
— Chip-to-chip time from	2,5 s	2,5 s
— Axis acceleration X-Y-Z max.	15 / 13 / 18 m/s ²	12 / 12 / 14 m/s ²
— Rapid feed max.	75 m/min	75 m/min
— Number of tools max..	162	2 x 80
— Tool taper	SK 40 / HSK-A63 / HSK-T63	HSK-A63 / HSK-T63
— Tool weight max.	10,0 kg	10,0 kg
— Tool diameter max.	160 mm	160 mm
— Tool length max.	450 mm	450 mm
— Automatic workpiece change		3,5 s



FZ 16 S five axis: The single spindle machine is designed for precise 5-axis machining. Industry-leading dynamics result in a machine that truly shines, ensuring maximum productivity for each application. In short: Produce more parts, with unrivaled precision.

DZ 16 W: The double-spindle machine with workpiece changing device allows loading and unloading while machining – the ultimate competitive advantage for high volume production. With even greater dynamics, this machining center produces complex parts with unprecedented precision. In short: Highly precise parts at maximum productivity.

Spindles & spindle systems
Automatic tool changer
Table options



		FZ	CHAIN	FZ 16 S five axis	FZ 16 W				
		DZ	CHAIN	DZ 16 S five axis	DZ 16 W				

Flexible work areas and maximum paths:
X=660, Y=660, Z=400 mm

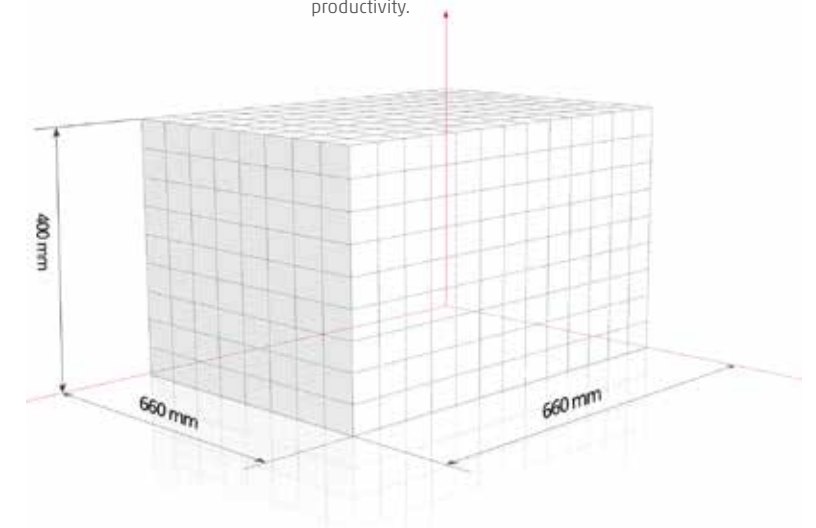

VariocellPallet: Automatic machining of complex workpieces

An innovative solution, specially developed for the new FZ/DZ 16 series

With the objective of processing small batch sizes more dynamically and flexibly. VariocellPallet enables various raw parts to be clamped on a rotary indexing table with up to ten prefabricated pallets. The handling system supplies raw part after raw part to the machining center and removes the workpieces together with the pallet following the successful machining process. This significantly increases productivity. Additional benefit: While one pallet is being processed, a second can be loaded in parallel.

One particularly attractive feature of VariocellPallet is the flexible operator access to the machining center: The motorized transfer trolley with rollers can be moved in three directions without needing rail systems. The pallet automation does not require much space and can be loaded and unloaded manually if necessary. An alternative automation solution for the FZ/DZ 16 is the modular, customer-specific configurable Variocell-System.

Size and composition

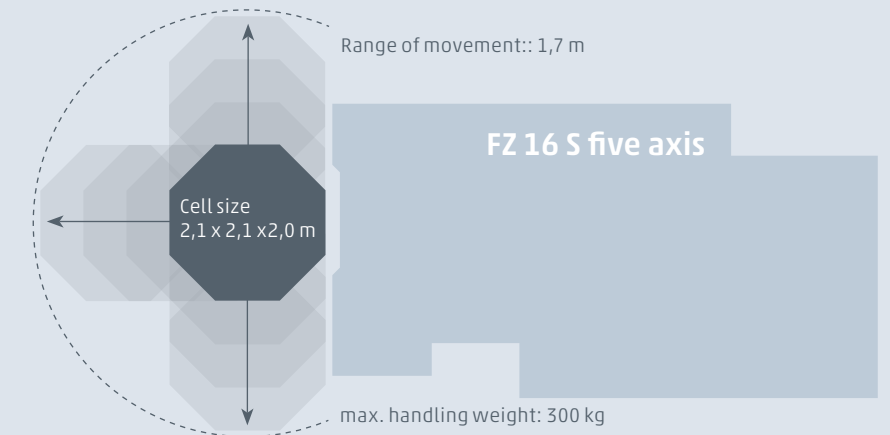

Pallet spaces

2.000 x 2.000 mm

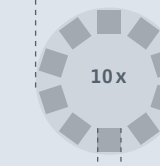

320x320 mm

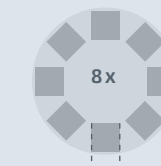

400x400 mm

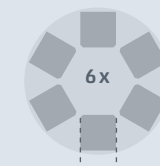

500x500 mm

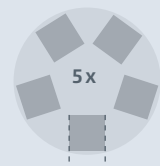

500x500 mm





CHIRON TURNKEY

- Comprehensive process design
- Expert engineering
- Experienced project management
- Validation of statistical process capability
- Ensuring targeted productivity
- Production assistance during the initial phase
- Training in operation and programming
- CHIRON Service available around the world



Turnkey customization completely from one source

Individual automation and engineered solutions for greater productivity

VariocellUno:

Flexible and inexpensive: a compact machining center, handling robot, workpiece storage and workpiece changing device (0°/180°) for loading and unloading during machining.

Customized automation solutions:

- Machine-integrated spindle grippers
- Portal and articulated-arm solutions
- Load and unload devices
- Pallet changing systems
- Pallet storage for raw and finished parts
- Interlinked systems and much more

Analyzing

Designing

Detailing

Implementing

Profiting

Your advantages with CHIRON VariocellUno:

- Integrated automation in the smallest possible space (< 1 sq. meter)
- Machine and automation as a unit –no safety fence
- Simple installation and set-up, as well as in-plant repositioning
- High efficiency for more profit
- High storage capacity
- Simple operation and programming
- Raw and finished part pallets can be replaced during machining
- Double gripper robot for quick workpiece change (option)
- Integrated measuring part discharge (for instance SPC parts)
- Unrestricted access to the work area in the manual mode
- Robots can be used for additional tasks

Today, manufacturing excellent machining centers is not enough. Users expect a solution, which is as individual as it is intelligent. From one specific machining task, a „Turnkey process“ is to be developed around the workpiece based on the specifications and constraints. The CHIRON TURNKEY makes it possible to optimally solve complex tasks.

Together with perfectly adapted technology modules, CHIRON engineers create the most economical solution from one source to meet the customer's special needs. This ensures decisive competitive advantages for CHIRON customers. CHIRON not only offers the machining solution itself, but also the support to keep manufacturing running at an optimal level.

SmartLine

The path to „Digitally enhanced machining“ is prepared

Intelligent machine control, digital networking, mutual machine communication, if „Digitally enhanced machining“ is mentioned, CHIRON may already has something to say. With the SmartLine program, the CHIRON Group provides a modular software system that enables customers to unlock the full potential of the digital manufacturing process.



Machine
TouchLine, ProtectLine,
ConditionLine



Factory
DataLine, ProcessLine,
ConditionLine



Cloud
Remoteline,
ConditionLine

An overview of all modules

ConditionLine

- Constant monitoring and analysis of the machine condition
- Early detection of unusual operation behavior
- Customized degree of networking

ProtectLine

- Collision monitoring in all types of operation
- Preventative collision protection
- Safety during machining

TouchLine

- Context-sensitive information
- Machine-specific support
- User-guided operation

Remoteline

- Machine remote access
- Rapid assistance in event of fault
- Automatic notifications
- Optimum data security

DataLine

- Visualization of machine condition and process progress
- Configurable system
- Real-time information about all machinery

ProcessLine

- Digital twin and post-processor
- „Digital“ process run-in
- Collision-tested NC program

User

Maintenance engineer
Service

Machine operator
Maintenance engineer

Machine operator
Installer
Maintenance engineer

Customer maintenance
engineer
Service

Production planner
Head of manufacturing
Controlling

Production planner

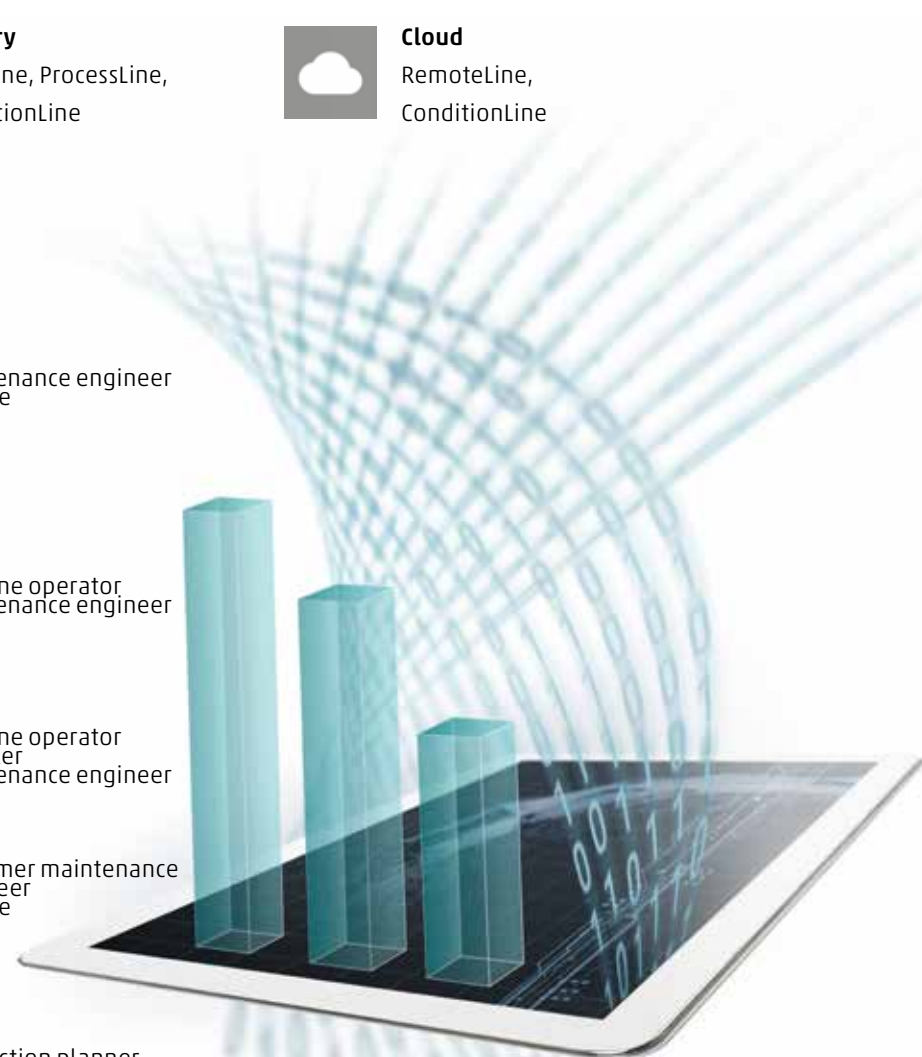

CHIRON training courses and training are available for the following topics

- Service and maintenance
- Operation
- Programming
- Components
- Robot
- Customer-specific

Trainings & workshops

Ahead through qualification, because knowledge leads to success.

To enable you to use your CHIRON CNC machining center optimally, we offer a comprehensive range of qualification measures, training courses and training for operators, setup personnel and service technicians.

The training programme is characterised above all by flexibility in implementation. In addition to the courses in our CHIRON training centre, these can also take place at your location. Our trainers are able to offer courses in German and English. Optionally we offer further languages with the help of an translator.

In the CHIRON Training Center, we get interested persons, both beginners and pros, up-to-date with the latest technology, step by step. With a number of individually combinable machine courses and programming courses. In this way we qualify your employees while increasing the productivity of your CHIRON CNC machining center. This leads to more success for your company, since qualified and motivated employees are an important success factor.

Our training courses are designed didactically according to the latest teaching methods. By doing practical work in small groups, we take into account the field of interest and the level of knowledge of the participants. Our philosophy is to strongly qualify the participants through their own work on our training objects. Subsequently, what has been learned can be directly put into practice in routine work.



Members of the CHIRON Group



CHIRON Werke GmbH & Co. KG
Kreuzstraße 75
78532 Tuttlingen, Germany
www.chiron.de



STAMA Maschinenfabrik GmbH
Siemensstraße 23
73278 Schlierbach, Germany
www.stama.de



SCHERER Feinbau GmbH
Marie-Curie-Straße 25
63755 Alzenau, Germany
www.schererfeinbau.de



CMS-GmbH
Gewerbepark »take off« 125
78579 Neuhausen o. E., Germany
www.cms-retrofit.de

CHIRON Group worldwide

FRANCE	Villeneuve-la-Garenne	CHINA	Beijing, Taicang
ITALY	Rodano Millepini	USA	Charlotte, Plymouth
POLAND	Paniówki	MEXICO	Querétaro
TURKEY	Istanbul	INDIA	Bangalore

Representatives